



EMPIRE[®]
BATTLE TESTED

EMPIRE BT-4 SERIES MARKERS

OWNER'S MANUAL

OMEGA™

COMBAT™

ERC™

DELTA™

DELTA ELITE™

RIP CLIP™

ELECTRONIC GRIP

APEX™ BARREL SYSTEM

WWW.EMPIREPAINTBALL.COM



EMPIRE BT-4 SERIES MARKERS

CONTENTS

1. RULES FOR SAFE MARKER HANDLING	1
2. INTRODUCTION AND SPECIFICATIONS	1
3. GETTING STARTED	1
4. FIRING YOUR MARKER	4
5. VELOCITY ADJUSTMENT	4
6. ELECTRONIC GRIP OPERATION (SOME MODELS)	5
7. RIP-CLIP OPERATION (SOME MODELS)	5
8. APEX BARREL OPERATION (SOME MODELS)	6
9. ACCESSORY ADJUSTMENTS	7
10. UNLOADING YOUR MARKER	7
11. REMOVING AIR SUPPLY	7
12. CLEANING MARKER	8
13. STORAGE AND TRANSPORTATION	8
14. DISASSEMBLY / REASSEMBLY	8
15. TROUBLESHOOTING	11
16. PARTS LIST & DIAGRAMS	12
WARRANTY	(Inside Back Cover)



The following is applicable to the Delta and the Delta Elite products only.
Authorized by Umarex, the worldwide exclusive H&K licensee for paintball products.

Ce qui suit est applicable à la Delta et les produits Delta Elite seulement.
Agréé par Umarex, le distributeur titulaire de licence exclusive mondiale H&K pour
produits de paintball.

La siguiente es aplicable a la Delta y Delta Elite de los productos solamente.
Aprobado por Umarex, el distribuidor con licencia mundial exclusiva H&K para
productos de paintball.

For manuals and warranty details, go to: paintballsolutions.com

For manuals in other languages, (where applicable), go to: paintballsolutions.com

©2011 Empire Paintball. The Empire Logo, and "Battle Tested" are trademarks of
Empire Paintball. All rights reserved. Empire Battle Tested is a brand of K&E Action
Sports, LLC.



EMPIRE BT-4 SERIES MARKERS

1. Rules for Safe Marker Handling

IMPORTANT: Never carry your Marker uncased when not on a playing field. The non-playing public and law enforcement personnel may not be able to distinguish between a paintball marker and firearm. For your own safety and to protect the image of the sport, always carry your Marker in a suitable marker case or in the box in which it was shipped.

- Treat every marker as if it were loaded.
- Never look down the barrel of a paintball marker.
- Keep your finger OFF the trigger until ready to shoot.
- Never point the marker at anything you don't wish to shoot.
- Keep the marker on "safe" until ready to shoot.
- Keep the barrel blocking device in/ on the marker's barrel when not shooting.
- Always remove paintballs and propellant source before disassembly.
- After removing air source, point marker in safe direction and discharge until marker is degassed.
- Store the marker unloaded and degassed in a secure place.
- Follow warnings listed on the air source for handling and storage.
- Do not shoot at fragile objects such as windows.
- Every person within range must wear eye, face and ear protection designed specifically to stop paintballs and meeting ASTM standard F1776.
- Always measure your marker's velocity before playing paintball and never shoot at velocities in excess of 91.44 meters (300 feet-per-second).

Read this entire manual before loading, attaching a propellant source or in any way attempting to operate any Empire BT-4 Series marker.

NOTE: Eye protective devices designed specifically for paintball use must be worn by the operator and anyone within range.
©Empire Paintball, Inc.

Empire BT-4 Series Markers

No part of this document may be copied or reproduced without the prior written consent of Empire Paintball, Inc.

2. Introduction and Specifications

Congratulations on your selection of the Empire BT-4 Series paintball marker. Empire BT-4 Series markers are made to provide you with many years of reliable performance. Empire Paintball, Inc. is honored that you have chosen an Empire BT-4 Series marker as your marker of choice and hope you enjoy using this high quality product.

Specifications

Caliber68
Mechanical Action	Semi-Automatic
Electronic Grip Action.....	Semi-Automatic, Ramping and Full-Auto
Powered	CO2 or Compressed Air (HP Output)
Main Body Material.....	Aluminum

Empire BT-4 Series markers come with a removable barrel system. This feature allows the user to select a barrel that is most suitable for the playing conditions. Standard barrels are mirror-honed with a step-bore, porting and a stock length of 8 to 13.75 inches.

3. Getting Started

Safety and Safe marker handling are the most important aspects of paintball sports. Please practice each of the following steps with an unloaded marker before attempting to charge your marker with compressed air and paintballs.

Do not install an air cylinder or load paintballs into your Marker until you feel completely confident with your ability to handle your Marker safely.

Keep your finger out of the trigger guard and away from the trigger; point the muzzle of the marker in a safe direction at all times. Keep the marker in safety or turned off until ready to operate.

Always keep your Marker pointed in a safe direction. Always use a barrel plug or barrel blocking device. Always use paintball specific eye protection which meets or exceeds ASTM standards in any areas where paintball markers may be discharged. Remember that the ultimate safety device is you, the operator.



EMPIRE BT-4 SERIES MARKERS

Safe Mode (non-electronic models)

In this manual, you will see the term “SAFE” mode. The Power should be OFF (Fig. 3.1) on electronic grips, or the Safety should be set to “SAFE” (red marking will not be visible) Fig. 3.2. Make sure your marker is set to “SAFE” mode when indicated to do so.



Safe Mode (electronic models)

To determine if your marker is in the SAFETY OFF position for Electronic Grip Frames, you will see an illuminated GREEN light (Fig. 3.3). To determine if your marker is in the SAFETY ON position for the Electronic Grip Frame, there will NOT be an illuminated GREEN light (Fig. 3.4). Make sure your marker is in the “SAFETY ON” mode when indicated to do so.

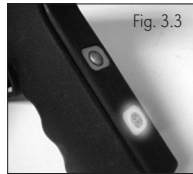

Barrel Installation (all models)

Make sure marker is degassed, hopper removed, no paintballs in the feed port or breech and the marker is in “Safe” mode.

1. While pointing marker in a safe direction, place the threaded end of the barrel into the front opening of the marker body (Fig. 3.5).
2. Turn the barrel clockwise until it stops (do not over tighten).
3. Adjust the barrel accessories if necessary.
4. Install a barrel blocking device. This can be a barrel plug or other such device that prevents the accidental discharge of a paintball.



Barrel Shroud Adjustment Instructions

If the barrel shroud needs an adjustment to line up with the marker body, follow these steps:

1. Locate the two set screws that hold the shroud in place, they are located on the right side of the shroud, when the barrel is pointed away from you.
 - a. The first is located on the front sight, in line with the barrel.
 - b. The second is along the side of the shroud, close to the marker body.
2. Use the 3/32" Allen wrench to loosen both screws (turn counter-clockwise). It is not necessary to remove them from the shroud.
3. Once both screws are loose and the shroud can move freely, line up the center mold line on top of the shroud with the center line of the body shells on top of the marker.
4. When aligned, tighten the two set screws using the 3/32" Allen wrench clockwise. Be careful not to over-tighten, or it will scratch the barrel! The marker is now ready for use.

Battery Installation/Replacement (some models)

Electronic Grip Battery Installation

1. Using a Phillips screwdriver, remove the two grip screws on the left side of the frame (Fig. 3.6).
2. Install a 9-volt battery into the electronic grip.
3. Re-install the two grip screws.



Rip Clip Battery Installation

1. Remove the screw on top of battery door (Fig. 3.7).
2. Install 4 x AA batteries following the polarity marking.
3. Reinstall the battery door screw.

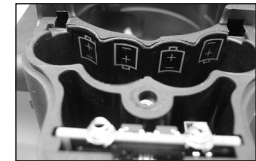

Note: Always use quality, name brand batteries. Using other types of batteries will affect the Rip-Clip™ and electronic grip's performance.



EMPIRE BT-4 SERIES MARKERS

Feed Elbow/Rip-Clip and Loader Installation Standard Feed Elbow

1. Press and hold the retention button located on the side of the Slide-Away™ elbow (Fig. 3.8).
2. Slide the elbow onto the front of the picatinny rail.
3. Line up the elbow with the feed hole on the right side receiver.
4. Check that the elbow is locked in place and properly aligned.



Fig. 3.8

Note: Spring-loaded retention button must line up in a gap on the picatinny rail.

Delta Feed Elbow (Fig. 3.9)

1. Loosen up the thumb nuts on the Delta elbow.
2. Clip onto the picatinny rail, left side first.
3. Make sure the feed holes are aligned.
4. Tighten up the thumb nuts.



Fig. 3.9

Standard Loader

1. To install a loader check the Slide-Away™ elbow / Delta elbow and loader to make sure they are free from debris and obstructions.
2. Position Slide-Away™ elbow / Delta elbow onto your marker's receiver.
3. If equipped with a clamping screw, use a 3/16" hex wrench, loosen the clamping screw on the Slide Away™ Elbow to allow the loader to slide into the top of the elbow.
4. If equipped with a clamping arm, release the arm to allow the loader to slide into the top of the elbow.
5. Press the loader into the opening of the Elbow until it stops.
6. Align the loader so that the lid is pointing to the rear and the loader is parallel with the marker.
7. Clamp the loader in place by using a 3/16" hex wrench or lock the clamping arm. Tighten the clamping screw on the Elbow until snug or close the clamping arm. Do not over tighten the loader.

Note: It might be necessary to adjust the clamping feed elbow screw to fit your loader. Using a 3/32" hex wrench, turn the screw clockwise to increase the clamping

force or counter-clockwise to decrease the clamping force.

Rip Clip™

1. Loosen up the thumb nuts on the Rip Clip™ (Figure 1).
2. Clip onto the picatinny rail, left side first (Figure 2).
3. Make sure the feed holes are aligned (Figure 3).
4. Tighten up the thumb nuts (Figure 4).



Figure 1



Figure 2



Figure 3



Figure 4

Rip Clip™ Loader

Insert the loader onto the Rip Clip™ as indicated. Turn the loader Counter-clockwise until it locked firmly.



Air Cylinder Installation (all models)

Consult the place where you purchased your Empire BT-4 Series Marker, or a recognized and competent air smith, for instruction in the safe handling of compressed-air cylinders before purchasing or connecting one to your Empire BT-4 Series Marker.

Before Pressurizing Your Marker

1. Check to make sure that you and anyone within range are wearing eye protection designed specifically for paintball.
2. Double check that all screws are tightened and no parts are loose before installing your tank.
3. Ensure you have a barrel plug, barrel sock or other specifically designed barrel-blocking device in place.
4. Make sure there are no paintballs in the marker.
5. Set marker to "SAFE" mode.



EMPIRE BT-4 SERIES MARKERS

Pressurizing your Marker

1. While pointing the marker in a safe direction, cock the marker by pulling the cocking knob located on the left side of the marker back until it clicks and stops.
2. Release the cocking knob, the marker is now cocked.
3. Locate the air cylinder adapter. The Empire BT-4 Series marker cylinder adapter is located at the base of the pistol grip.
4. Position the Empire BT-4 Series marker so that the air cylinder adapter is pointed upwards while keeping the muzzle of the marker pointed in a safe direction.
5. Insert the threaded cylinder valve end into the adapter (Fig. 3.10).
6. Without pushing the cylinder, twist the cylinder clockwise and allow the threads to draw the cylinder into the marker until it stops. Your marker is now charged.



Notes:

- Remember compressed air, nitrogen systems and CO2 cylinders can be extremely dangerous if misused or improperly handled. Use only cylinders meeting D.O.T. or regionally defined specifications.
- Never disassemble your tank or tank regulator. Only a qualified and trained technician should perform work on your tank and tank regulator.
- Never add any lubricants or greases into the fill adapter on your tank regulator.

Loading Paintballs (all models)

Empire BT-4 Series Markers use .68 Caliber, water-soluble paintballs, readily available at paintball pro-shops, commercial playing fields, and many sporting goods stores. The paintballs are feed from the loader through the feed elbow or Rip-Clip™ into the breech



of the marker.

1. Make sure the marker is set to "SAFE" mode.
2. Put on an eye protective device designed specifically for paintball and make sure that anyone within range of the marker does the same.
3. Load quality .68 caliber paintballs (leave some room for paintballs to move about, inside loader).

4. Firing Your Marker (all models)

Warning: Always keep your Marker pointed in a safe direction! Everyone within firing range should always use paintball approved eye and face protection in the presence of live paintball markers. Make sure the Marker is set to "SAFE" mode, before following the steps below.

Standard Mechanical Frame

- Place the empty loader onto the marker.
- Be sure that it is securely mounted in place.
- Cock the marker.
- Apply the air cylinder, pressurizing the marker.
- Put the paintballs into the loader.
- Turn on Rip Clip™ if equipped with one.
- Remove the barrel plug, sock or barrel-blocking device.
- Aim the Empire BT-4 Series marker in a safe direction.
- Set the Safety to the "Fire" position.
- Aim the Marker at the target.
- Place your finger on the trigger.
- Pull the trigger with a smooth squeezing motion.

Electronic Grip Instructions

- Place the empty loader onto the marker.
- Be sure that it is securely mounted in place.
- Cock the marker.
- Apply the air cylinder, pressurizing the marker.
- Put the paintballs into the loader.





EMPIRE BT-4 SERIES MARKERS

- Turn on Rip Clip™ if equipped with one.
- Remove the barrel plug, sock or barrel-blocking device.
- Aim the Empire BT-4 Series marker in a safe direction.
- Turn the Electronic Grip On (See Electronic Grip Operation section)
- Aim the Marker at the target.
- Place your finger on the trigger.
- Pull the trigger with a smooth squeezing motion.

5. Velocity Adjustment (all models)

Always check the velocity of the marker prior to playing paintball. Different playing fields may have different maximum velocity limits. At no time should you shoot at velocities above 300 feet-per-second.

1. Put on an eye protective device designed specifically for paintball and make sure that anyone within range of the Empire BT-4 Series marker does the same.
2. While pointing the marker in a safe direction, remove the barrel blocking device.
3. Point the Empire BT-4 Series marker over a chronograph that will measure the velocity of the paintballs discharged by the marker.
4. Set the marker to "FIRE" mode (Turn Electronic Grip on or turn safety off).
5. Pull the trigger and check the reading on the chronograph.
6. Locate the velocity adjuster screw on the left side of the marker.
7. Using a 5/32" hex key, turn the screw inward or clockwise to reduce the velocity, and outward or counterclockwise to increase the velocity of the paintballs discharged from the marker (Fig. 5.1).

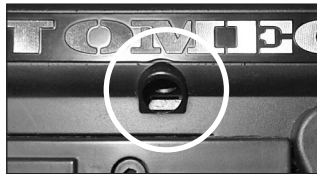

Fig. 5.1

DO NOT REMOVE THE VELOCITY ADJUSTMENT SCREW.

6. Electronic Grip Operation (some models)

The Electronic Grip has 3 different firing modes: Semi-Auto, Ramping, and Full-Auto. The modes are changed by removing the left-side grip and adjusting the dip switches located in the grip frame.

FIRING MODES

		1	2	
1. PSP RAMPING	(13 BPS)	OFF	OFF	
2. PSP RAMPING	(10 BPS)	OFF	ON	
3. NXL FULL AUTO	(13 BPS)	ON	OFF	
4. NXL FULL AUTO	(10 BPS)	ON	ON	

Above settings are with jumper ON. With jumper OFF, firing is semi-auto regardless of DIP settings.

The Electronic Grip comes in Ramping mode from the factory and the Jumper in the frame must be removed to lock the firing mode to semi-auto. The Electronic Grip has an automatic shut-off after 1 hour of inactivity.

Activating the Electronic Grip™

To activate the electronic grip, press the ON/OFF button on the back of the frame. A green LED will come on to show that the electronic grip is activated and ready to fire (Fig. 6.1).

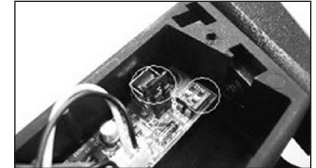

Fig. 6.1

Note: Always use name brand batteries. Using other types of batteries will affect the marker performance.

Adjusting the Sear Height

To adjust the sear height, there is a set screw in the lower vertical arm of the sear that contacts the front of the solenoid. If it is necessary to raise the sear to engage the rear bolt, insert a 0.50" allen wrench past the side of trigger and turn the allen wrench counter clockwise. Make adjustments while the trigger frame is off the receiver (body) and the marker is degassed. Look down from the top of frame to help locate the set screw. Only turn the Allen wrench 1/8 turn at a



Fig. 6.2



EMPIRE BT-4 SERIES MARKERS

time and check engagement after each adjustment. Once the sear begins to engage the rear bolt, turn the set screw an additional half to 1 full turn (Fig. 6.2).

7. Rip Clip™ Operation (some models)

Rip Clip™ Features and Specifications

Power requirements: 4AA batteries (not included)

Capacity: 200+ paintballs

Feed Rate: 20bps+

Construction: Nylon

Auto-Off 1 Hour

Low Battery Indicator

Ultra-Quiet Belt Drive

Note: Always use quality, name brand batteries. Using other types of batteries will affect the Rip Clip's performance.

Activating the Rip Clip™

Locate the power button on the rear control panel. To turn on, press the button. The green LED comes on while the button is pressed; now release button. The green LED will now flash again for one second, go off, then flash quickly 1, 2, or 3 times indicating the speed it is currently set to. The motor will spin for a second and the loader is now ready to use. DO NOT fire your marker until after the initial motor spin has completed. Firing during this period can disrupt the auto-adjusting sound sensitivity and cause the hopper not to work properly. The green LED will flash repeatedly while the unit is on to show it is ready. If the LED flashing changes to red, then the batteries are low and need to be replaced.

To turn off, press and hold until the loader gives a red indication. Release the button and loader will power down to the OFF state.

Setting the Speed

1. When the Rip Clip™ is first turned on, while the LED flashes for one long second, press and hold the power button again during this flash.

2. When done properly, the LED will now change to red and you can release the button.
3. The LED will only stay red for about 5 seconds, and then change back to its flashing green sequence for regular operation if no buttons are pressed.
4. To set the speed during the red LED phase, push and release the button the number of times necessary based on what speed you desire.
5. Press once for normal slow speed, twice for faster normal speed, and three times for fastest speed. Each time you press and release the button during this sequence, the press of the button should last about one second.
6. If done too quickly, the board may not be set to the speed you desire. When done correctly, the red LED will go off, then flash the same number of times the button was pressed, indicating which speed it is now set to.
7. The motor will now spin up at the speed it is set to, it will stop, and now the speed is set and the unit is ready to use.

Preloading the Rip Clip's Drive Cone Spring

If you take out the Rip Clip's drive carrier for cleaning, it will be necessary to preload the drive carrier spring for the Rip Clip™ to function correctly. Rotate the drive carrier clockwise until the upper and lower spring tabs hit each other. You should now have both spring tabs pressed together. Lift the drive carrier slightly and rotate it clockwise up and over the spring housing tab (taking the upper spring tab) with it. Snap the drive carrier down with the drive spring tab on the right side of the drive housings tab and install the top screw. The drive carrier spring is now pre-loaded and will snap back properly when wound up.

8. Apex™ Barrel Operation (some models)

The Apex barrel is the most advanced barrel in the world. You can adjust the barrel to shoot in different directions and set it to give you greater distance than any standard barrel.

Features

- On/Off capability.
- Hit previously untouchable targets with new curve feature.
- Adjustable ramp switch - choose the desired level of the curve.



EMPIRE BT-4 SERIES MARKERS

- Left hook, right hook, drop shot and long flat trajectory shots with a twist of the barrel.
- Easy to dial in targets and change the level of curve.

Setting the Apex™ Barrel Ramp

1. Start with the ramp in the OFF position (toward the back of barrel) (Fig. 8.1).
2. Follow all safety and paintball loading instruction for safe use.
3. Go to your fields shooting range or other approved area.
4. Gradually adjust the ramp forward until you see the balls start to change their trajectory. The further you move the Ramp forward; the balls will have higher degree of curve.



Fig. 8.1

Adjusting Direction of Shots

1. Adjust the Apex front by turning it.
2. Turning it right will give you a right hook.
3. Turning it left will give you a left hook.
4. Rotating it 180 degrees will give you a drop shot.
5. The standard position will give you a long shot.

Note: It will be necessary to adjust the Ramp setting on the Apex barrel to the paint you are using. Different brands/types of paintballs will have a slightly different size. This will affect the amount of curve you get.

9. Accessory Adjustments

Adjusting the Car-Stock (Omega model)

Push the stock adjustment lever up and adjust the stocks length by pulling or pushing on the back of the stock (Fig. 9.1).



Fig. 9.1

Adjusting the Delta Stock (Delta and Delta Elite models)

Push the stock adjustment lever to the left and adjust the stocks length by pulling or pushing on the back of the stock (Fig. 9.2).



Fig. 9.2

Vertical Foregrip Adjustment (Combat and ERC models)

1. Turn vertical foregrip retainer counter clockwise to allow retention pin to drop. A coin may be used to assist in turning the vertical foregrip retainer (Fig. 9.3).
2. Slide foregrip to preferred location.
3. Reverse process to tighten foregrip.

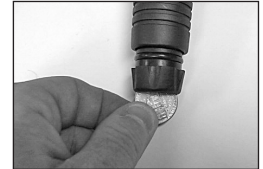

Fig. 9.3

Note: that the retention pin must line up in a gap on the picatinny rail.

Magazine Adjustment (Omega, Delta, and Delta Elite models)

1. Remove the 2 screws (Omega Model) (Fig. 9.4) and locking metal plate. (Metal plate applies to Delta and Delta Elite models) (Fig. 9.5).
2. Slide the magazine assembly to new location.
3. Reinstall the plate and screws, making sure they are going into a Picatinny notch.
4. Tighten screws.



Fig. 9.4

10. Unloading Your Marker

1. Put on an eye protective device designed specifically for paintball and make sure that anyone within range of the Empire BT-4 Series Marker does the same.
2. Make sure the barrel blocking device is properly installed and the marker is set to "safe" mode.
3. Loosen the loader clamping screw or release clamping arm.
4. While holding the paintball hopper in place, invert the marker



Fig. 9.5



EMPIRE BT-4 SERIES MARKERS

so that the hopper is below the Empire BT-4 Series marker.

5. Remove the loader and all paintballs.
6. While pointing the Empire BT-4 Series marker in a safe direction, remove the barrel blocking device.
7. Keep the Empire BT-4 Series marker pointed in a safe direction and pull the trigger several times to insure there are no balls remaining in the chamber or the barrel.
8. Properly re-install the barrel blocking device and set the marker is set to "SAFE" mode.

11. Removing Air Cylinder

1. Make sure the barrel blocking device is properly installed and the Empire BT-4 Series marker is set to "SAFE" mode.
2. Point the Empire BT-4 Series marker in a safe direction and turn the cylinder counter clockwise about 3/4 of a turn. This allows the cylinder valve to close without damaging the cylinder o-ring.
3. While pointing the Empire BT-4 Series marker in a safe direction, disengage the safety (set to "fire").
4. Keeping the BT marker pointed in a safe direction, pull the trigger until the remaining CO2 or air is expelled and it fails to re-cock.
5. Unscrew the cylinder from the Empire BT-4 Series marker.
6. The marker is now ready to be cleaned or put away for future use.

12. Cleaning Marker

Once your Empire BT-4 Series Marker is unloaded and the air cylinder is removed, you can use a damp cloth to wipe off paint, oil, dirt and debris. You can also use warm water to rinse the marker clean. Once your marker is clean and dry you can re-oil using a light, premium marker oil. (Note: Petroleum based and aerosol products can damage your markers o-rings. **DO NOT USE ANY PETROLEUM BASED OR AEROSOL PRODUCTS ON YOUR MARKER.** To access the rear bolt and linkage arm you must remove the left receiver half. (See the disassembly section.)

13. Storage and Transportation

When you are finished using your Empire BT-4 Series marker it is important that you prepare it for storage. This will not only serve to increase the life of the marker, but will assure optimum performance on your next outing.

- The Empire BT-4 Series marker must be clear of all paint and propellant when not being used.
- Be sure to have marker in "SAFE MODE" when not in use.
- Make sure barrel blocking device is in place.
- Store Empire BT-4 Series marker and propellant in cool dry place.
- Keep your Empire BT-4 Series marker away from children without proper supervision.
- Your Empire BT-4 Series marker must be free of all paint and not attached to a propellant source while being transported to and from the playing field.
- Observe and obey all local, state and federal laws concerning the transportation of paintball markers. For information concerning any of the laws in your area, contact your local law enforcement.
- Always store the marker in a secure location when not in use so as to prevent access by unauthorized persons.

IMPORTANT: Never carry your Empire BT-4 Series Marker uncased when not on a playing field. The non-playing public and law enforcement personnel may not be able to distinguish between a paintball marker and firearm. For your own safety and to protect the image of the sport, always carry your Empire BT-4 Series Marker in a suitable marker case or in the box in which it was shipped.

14. Disassembly/Reassembly

CAUTION: Before attempting to perform any maintenance operations, make sure that all paintballs and propellant sources have been removed from the marker. Install a barrel blocking device, Marker must be unloaded, degassed and un-cocked before any disassembly or maintenance. Follow unloading and removing air supply steps.

Disassembly Tips

- Make sure you have a clean area to work on your marker.
- When separating the Shell for the first time, do so carefully, so you do not lose any parts.
- Visit PaintballSolutions.com for additional information.



EMPIRE BT-4 SERIES MARKERS

Barrel Removal (all models)

Turn the barrel counter clockwise to remove it from the marker. Keep your barrel clean for best results.

Feed Elbow and Rip Clip™ Removal *Slide-Away™ Elbow*

1. Press and hold the retention button located on the name plate side of the Slide-Away™ Elbow (Fig. 13.1).
2. Slide the Elbow toward the front of the marker and remove.
3. Reverse process to replace Slide-Away™ Elbow.

Delta Feed Elbow

1. Loosen the two thumb nuts.
2. Lift the feed elbow away from the receiver.
3. Lift off the receiver.

Rip Clip™

1. Loosen the two thumb nuts.
2. Lift the Rip Clip™ away from the receiver.
3. Lift off the receiver.



Fig. 13.1

Front Foregrip Removal

1. Turn the vertical foregrip bolt counter clockwise to allow retention pin to drop. A coin may be used to assist in turning the vertical foregrip bolt (Fig. 13.2).
2. Slide foregrip to preferred location or remove if so desired.
3. Reverse process to replace foregrip.

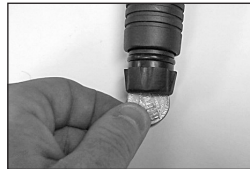

Fig. 13.2

Sight Rail Removal (Omega Model)

Rear Notch Sight

1. Using a 1/8" Allen wrench, loosen the rear sight retaining screw (Fig. 13.3).
2. Slide sight off the picatinny rail.

Delta Sight Rails

1. Remove the Delta Feed Elbow / Rip Clip™ and barrel assembly.
2. Slide the small front sight rail forward and off the receiver.
3. Loosen the 3 screws with a Phillips screwdriver on the left side of the rear sight rail.
4. Slide the sight rail toward the back of the marker and remove.



Fig. 13.3

Note: It may not be necessary to loosen the 3 screws on the Delta rear sight; see if it slides off first.

Trigger Frame Removal (all models)

1. Extend the stock on all Delta and Omega models.
2. Remove the two grip retention screws from the pistol grip.
3. If the acorn shoulder nuts located in the pistol grip do not fall out after the screws are removed, then press them out with a small hex wrench or screwdriver.
4. Lower the frame from the receiver.

Note: The frame will still be attached to the receiver by the steel braided hose. It is recommended that you do not remove the hose from the valve or the tank adapter.





EMPIRE BT-4 SERIES MARKERS

Receiver (Body) Separation (all models)

To fully access the internal receiver components, these parts must be removed first:

- Barrel
- Feed Elbow /Rip clip
- Sight rails
- Foregrip/Magazine
- Grip frame

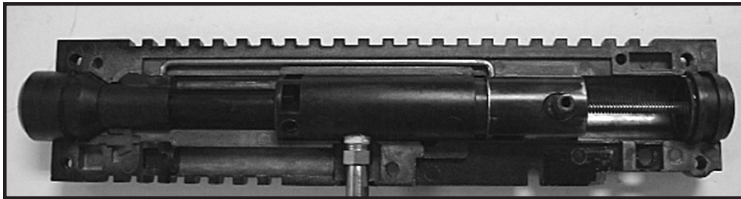

Make sure the marker is in the un-cocked (forward position) before taking body apart.

1. Remove the bolt handle cover (rubber bonnet).
2. Lay on a flat surface with the left name plate facing up.
3. Remove the four upper receiver retention screws.
4. Lift name plate receiver away from other receiver half.

Note: The end cap/stock will be under some spring tension and may spring out when the top name plate receiver is lifted off.

Note: The retention screw located below the bolt handle slot is longer than the rest.

Removing End Cap/Stock, Spring Guide, Bumper and Spring

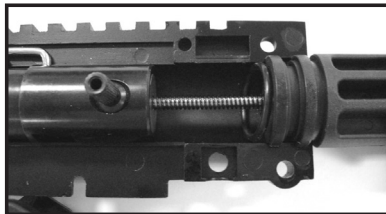

1. Lift end cap/stock out of the right upper receiver.
2. Remove the bumper O-ring.
3. Remove spring and spring guide.

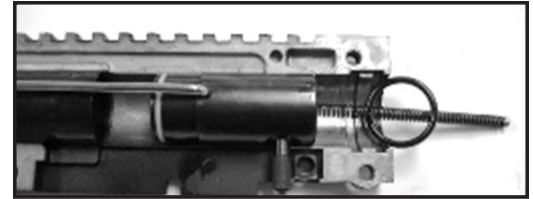

Removing Rear Bolt, Cocking Handle and Linkage Arm

1. Rotate rear bolt counter-clockwise.
2. Remove linkage arm.
3. Remove bolt handle.
4. Slide the rear bolt rearward and remove.

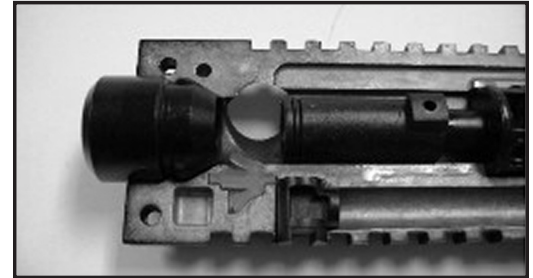

Removing Barrel Adapter, Ball Detent and Front Bolt

1. Lift away Barrel Adapter (and barrel if still installed).
2. Lift out Ball Detent; notice its position before removing it.
3. Slide the Front Bolt forward and off the power tube.

Reassembly

To reassemble the marker, reverse the Disassembly instructions starting with the barrel adapter, ball detent and front bolt removal. While reassembling the marker, you should oil all O-rings and sliding parts. All parts and o-rings returned to the marker should be free of debris and visual nicks and scratches which can alter the performance of the marker. All screws returned to the marker must be tightened so there is no chance of them vibrating loose.



EMPIRE BT-4 SERIES MARKERS

PROBLEM	DIAGNOSIS	SOLUTION
Marker double firing or going full auto	<ul style="list-style-type: none"> • Air cylinder low on air • Rear bolt o-ring worn or damaged • Rear bolt or sear worn • Rear bolt has no oil • Bad valve • Sear height is improperly adjusted 	<ul style="list-style-type: none"> • Get air cylinder filled • Replace rear bolt o-ring • Inspect both for wear and replace if needed • Oil rear bolt o-ring area with paintball oil • Service or replace valve • Adjust sear height (Electronic Grip models only)
Marker does not re-cock	<ul style="list-style-type: none"> • Rear bolt o-ring worn or damaged • Rear bolt o-ring is dry • Power tube is damaged • Sear height is improperly adjusted • Marker internals clogged 	<ul style="list-style-type: none"> • Replace rear bolt o-ring • Oil rear bolt o-ring area with paintball oil • Replace power tube • Adjust sear height (Electronic Grip models only) • Clean dirt and/or broken paintballs from inside receiver and barrel
Marker leaking out of barrel	<ul style="list-style-type: none"> • Valve leaking 	<ul style="list-style-type: none"> • Service or replace valve
Marker leaking at ASA	<ul style="list-style-type: none"> • Tank o-ring damaged or missing • Tank or ASA damaged 	<ul style="list-style-type: none"> • Replace tank o-ring • Replace tank and/or asa if needed
Electronic Grip is not working	<ul style="list-style-type: none"> • Battery is low on power • Battery is of low quality • Sear height is improperly adjusted • Board connectors are loose • Electronics are damaged 	<ul style="list-style-type: none"> • Install new battery • Buy better name brand batteries • Adjust sear height • Check that connectors are plugged in fully • Replace damaged parts
Rip-Clip™ is not working	<ul style="list-style-type: none"> • Battery is low on power • Battery is of low quality • Batteries are installed incorrectly • Drive cone is not pre-loaded • Rip-Clip™ not properly aligned on marker 	<ul style="list-style-type: none"> • Install new battery • Buy better name brand batteries • Check the polarity markings • Pre-loaded drive cone spring • Position so feed holes match up
Marker is breaking paint	<ul style="list-style-type: none"> • Velocity is too high • Paint is of low quality or old • Ball detent damaged or backwards • Apex barrel is dirty • Apex ramp is set to high 	<ul style="list-style-type: none"> • Lower velocity by turning screw clockwise • Try better fresh paint • Replace detent or check if its in backwards • Clean apex barrel • Lower the ramp setting
Marker is double feeding	<ul style="list-style-type: none"> • Ball detent is damaged 	<ul style="list-style-type: none"> • Replace ball detent
Paintballs not feeding into marker	<ul style="list-style-type: none"> • Rip-Clip™ not installed correctly • Rip-Clip™ is not turned on 	<ul style="list-style-type: none"> • Check Rip-Clip™ is installed correctly • Turn on Rip-Clip™
Velocity is low (Do NOT Exceed 300 FPS)	<ul style="list-style-type: none"> • Velocity screw is in too far • Air source is low • Power tube is damaged • Drive spring is weak 	<ul style="list-style-type: none"> • Turn the screw counter-clockwise to increase velocity • Get air cylinder filled • Replace power tube • Install a stiffer drive spring
Velocity is high (Do NOT Exceed 300 FPS)	<ul style="list-style-type: none"> • Velocity screw is out too far • Drive spring is too stiff 	<ul style="list-style-type: none"> • Lower velocity by turning screw clockwise • Install a lighter drive spring



EMPIRE BT-4 SERIES MARKERS

Empire BT Feednecks Parts List

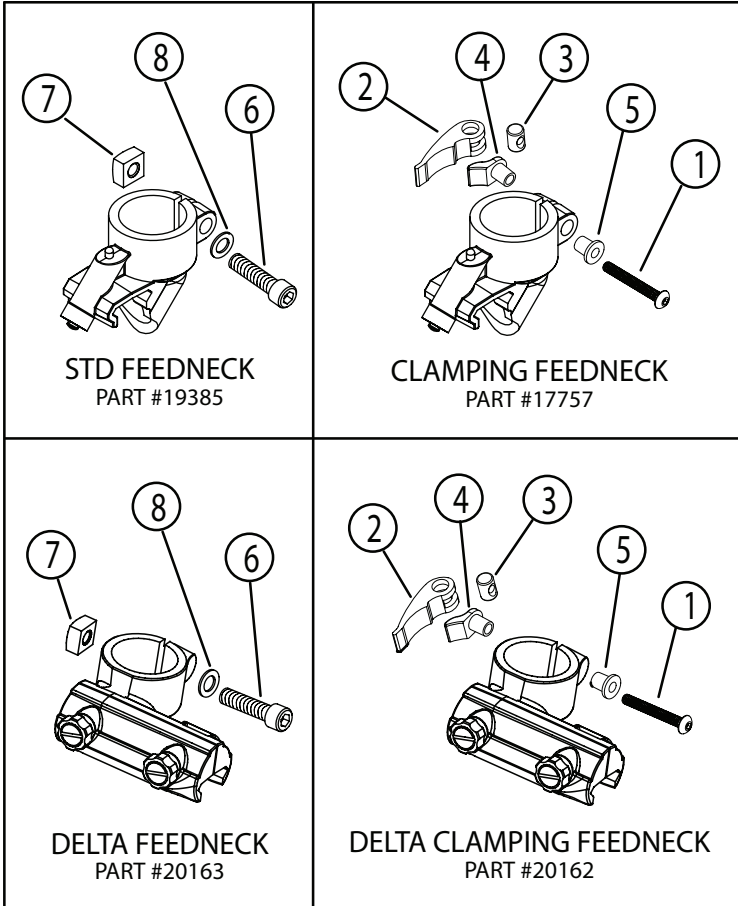

SCHEMATIC#	DESCRIPTION	SKU#
1	Clamping Feed Elbow Screw	17759
2	Clamping Feed Elbow Lever	17760
3	Clamping Feed Elbow Collar	17761
4	Clamping Feed Elbow Seat	17762
5	Clamping Feed Elbow Spacer	17763
6	Standard Feed Elbow Pinch Bolt	19420
7	Standard Feed Elbow Nut	19421
8	Standard Feed Elbow Washer	19422
	Clamping Feed Elbow (complete)	17757
	Standard Feed Elbow (complete)	19385
	Delta Clamping Feedneck	20162
	Delta Standard Feedneck	20163



EMPIRE BT-4 SERIES MARKERS

Empire BT Rip Clip™ Parts List

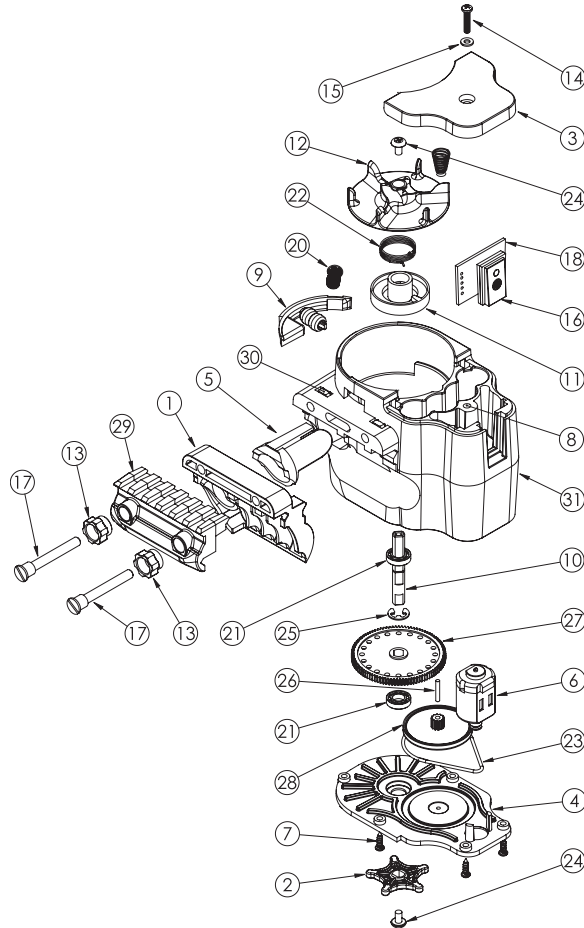

SCHEMATIC#	DESCRIPTION	SKU#
1	TM-15 Adapter Plate	17852
1	TM-7 Adapter plate	38449
2	Rip Drive 2 Wheel	31023
3	Battery Cover Assembly	38413
4	Bottom Cover	38416
5	Ball Sleeve	38421
6	Motor w/ Harness	38423
7	Bottom Cover Screw	38425
8	Battery Cover Nut	38426
9	Anti Jam Assembly	38427
10	Drive Shaft	38428
11	Spring Housing	38429
12	Drive Carrier	38430
13	Rail Locking Thumb Nut	38433
14	Battery Cover Screw	38435
15	Battery Cover Washer	38436
16	On/Off Button Pad	38442
17	Rail Locking Screw Long TM Marker	38445
17	Rail Locking Screw Short BT-4 & Omega Markers	38432
18	TM Circuit Board	38448
20	Anti Jam Spring	38800
21	Bearing	38803
22	Drive Cone Spring	38814
23	Drive Belt	38820
24	Drive Shaft Screw	38822
25	E-Clip	38823
26	Pulley Gear Pin	38828
27	Sprocket Gear	38830
28	Pulley Gear	38837
29	Pictinny Locking Rail	38395
30	Locking Rail Nut	38396
31	Rip-Clip RF Body	38397
not shown	Battery Polarity Sticker	38438
not shown	Battery Spring Tab Screw	38440
not shown	Battery Spring Tab	38441
optional	Empire RF Transmitter Link Kit	38926



EMPIRE BT-4 SERIES MARKERS

Empire BT Combat™ Parts List

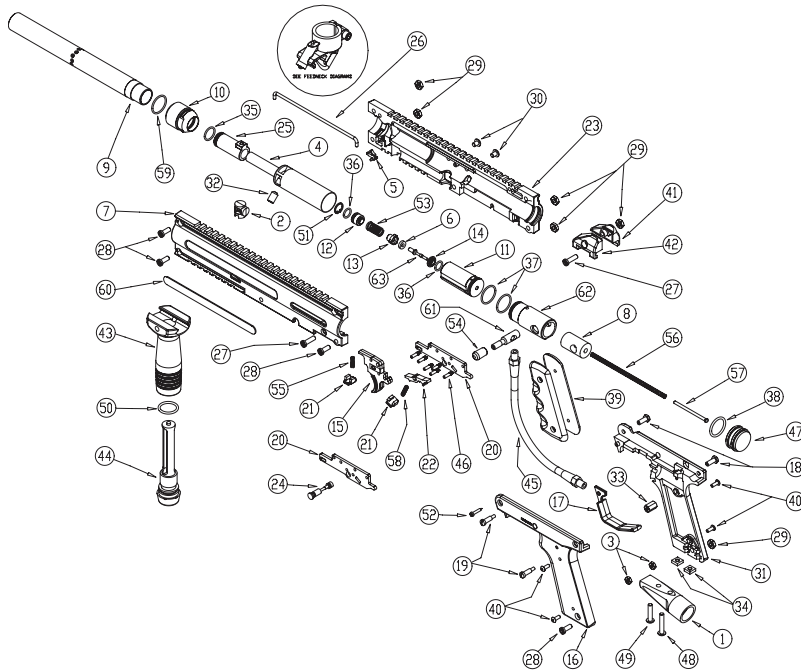

SCHEMATIC#	DESCRIPTION	SKU#	SCHEMATIC#	DESCRIPTION	SKU#
1	Tank Adapter	17044	37	Rear Bolt & External Valve O-Ring	19426
2	Expansion Chamber Plug	17045	38	Shock Absorber O-Ring	19427
3	Lower Grip Nut	19383	39	45 Rubber Grip	19429
4	Power tube	19384	40	Grip Screws	19430
5	Ball Detent	19386	41	Right Rear Sight	19431
6	Cup Seal	19387	42	Left Rear Sight	19432
7	Left upper Receiver	19388	43	Front Grip	19433
8	Bolt Plug	19389	44	Front Grip Bolt	19434
9	Barrel	19390	45	Gas Line	19435
10	Barrel Adapter	19391	46	Trigger Plate Dowel Pins	19436
11	Valve Body	19392	47	Endcap	19437
12	Internal valve seat	19393	48	Long Tank Adapter Bolt	19439
13	Plunger Cup	19394	49	Short Tank Adapter Bolt	19440
14	Rear Valve Seat	19395	50	Front Grip O-Ring	19441
15	Single Trigger Assembly	19396	51	Valve Snap Ring	19442
16	Left Lower Receiver	19397	52	Trigger Guard Screw	19443
17	Trigger Guard	19399	53	Internal Valve Spring	19444
18	Lower Receiver Acorn Nut	19400	54	Bolt Handle Rubber Cover	19445
19	Lower Receiver Screw	19401	55	Trigger Return Spring	19446
20	Trigger Plate	19402	56	Drive Spring	19447
21	Trigger Plate Spacer	19404	57	Drive Spring Guide	19448
22	Sear	19405	58	Sear Spring	19449
23	Right Upper Receiver	19406	59	Barrel Adapter O-Ring	19452
24	Safety with O-rings	19407	60	Empire BT-4 Combat Name Plate	19453
25	Front Bolt	19409	61	Bolt handle	19454
26	Linkage Arm	19410	62	Rear Bolt	19455
27	Long Receiver Bolt	19413	63	Valve Stem	99126
28	Short Receiver Bolt	19414	not shown	Rear Sight Assembly (Complete)	17700
29	Receiver Nuts	19415	not shown	Rental Name Plate Green	17048
30	Valve Screw	19416	not shown	Rental Name Plate Yellow	17049
31	Right Lower Receiver	19417	not shown	Rental Front Grip Green	17043
32	Velocity Screw	19418	not shown	Front Grip Yellow	17047
33	Grip Upper Hex	19419	not shown	Complete Valve Assembly	19382
34	Tank Adapter Nuts	19423	not shown	Master Parts Kit (for fields)	19375
35	Front Bolt O-Ring	19424	not shown	Player Parts Kit	19376
36	Internal Valve O-Ring	19425			



EMPIRE BT-4 SERIES MARKERS

Empire BT ERC™ Parts List

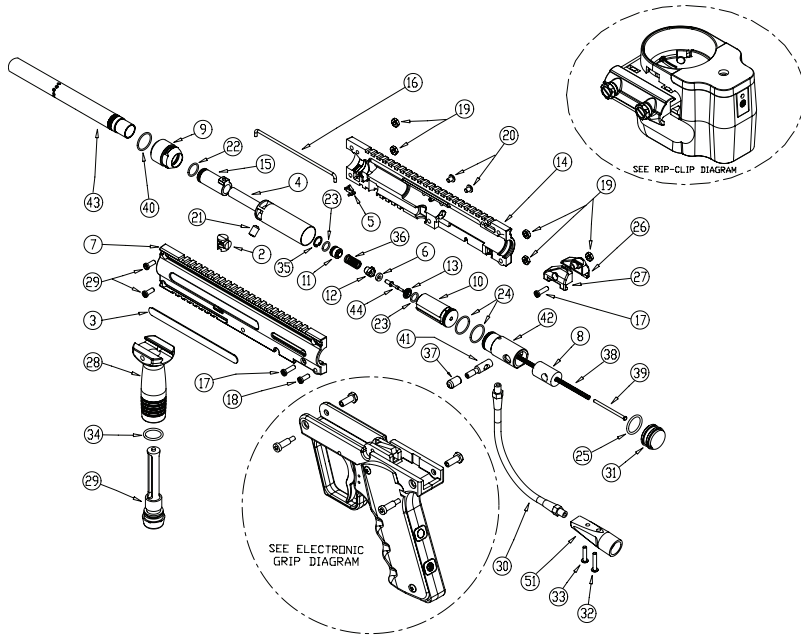

SCHEMATIC#	DESCRIPTION	SKU#	SCHEMATIC#	DESCRIPTION	SKU#
1	Tank Adapter	17044	31	Endcap	19437
2	Expansion Chamber Plug	17045	32	Long Tank Adapter Bolt	19439
3	ERC Name Plate	17056	33	Short Tank Adapter Bolt	19440
4	Power tube	19384	34	Front Grip O-Ring	19441
5	Ball Detent	19386	35	Valve Snap Ring	19442
6	Cup Seal	19387	36	Internal Valve Spring	19444
7	Left upper Receiver	19388	37	Bolt Handle Rubber Cover	19445
8	Bolt Plug	19389	38	Drive Spring	19447
9	Barrel Adapter	19391	39	Drive Spring Guide	19448
10	Valve Body	19392	40	Barrel Adapter O-Ring	19452
11	Internal valve seat	19393	41	Bolt handle	19454
12	Plunger Cup	19394	42	Rear Bolt	19455
13	Rear Valve Seat	19395	43	Barrel	19390
14	Right Upper Receiver	19406	44	Valve Stem	99126
15	Front Bolt	19409	not shown	Rear Sight Assembly (Complete)	17700
16	Linkage Arm	19410	not shown	Complete Valve	19382
17	Long Receiver Bolt	19413			
18	Short Receiver Bolt	19414			
19	Receiver Nuts	19415			
20	Valve Screw	19416			
21	Velocity Screw	19418			
22	Front Bolt O-Ring	19424			
23	Internal Valve O-Ring	19425			
24	Rear Bolt & External Valve O-Ring	19426			
25	Shock Absorber O-Ring	19427			
26	Right Rear Sight	19431			
27	Left Rear Sight	19432			
28	Front Grip	19433			
29	Front Grip Bolt	19434			
30	Gas Line	19435			



EMPIRE BT-4 SERIES MARKERS

Empire BT Delta™ Parts List

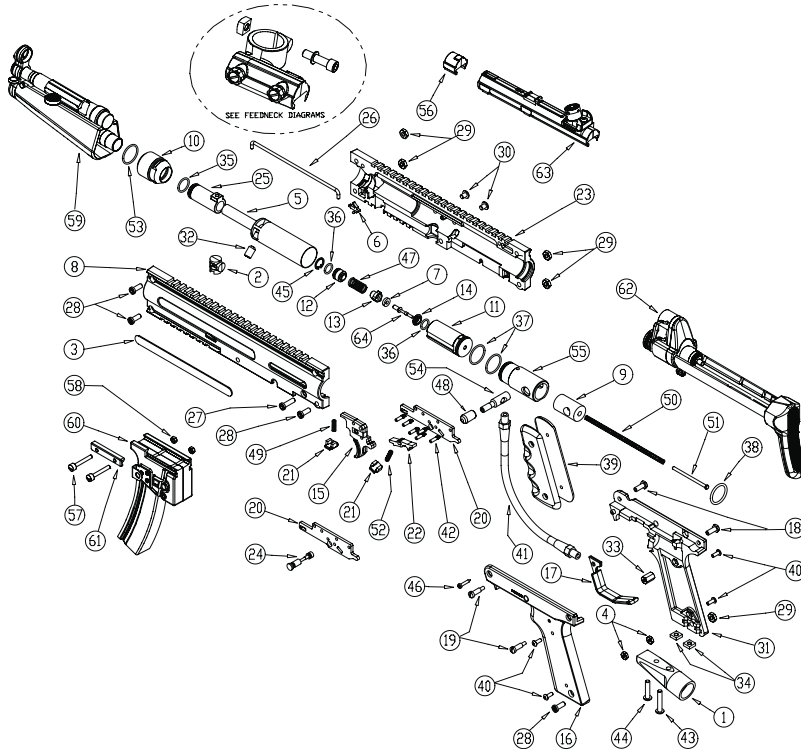

SCHEMATIC#	DESCRIPTION	SKU#	SCHEMATIC#	DESCRIPTION	SKU#
1	Tank Adapter	17044	36	Internal Valve O-Ring	19425
2	Expansion Chamber Plug	17045	37	Rear Bolt & External Valve O-Ring	19426
3	Delta Name Plate	17054	38	Shock Absorber O-Ring	19427
4	Lower Grip Nut	19383	39	45 Rubber Grip	19429
5	Power tube	19384	40	Grip Screws	19430
6	Ball Detent	19386	41	Gas Line	19435
7	Cup Seal	19387	42	Trigger Plate Dowel Pins	19436
8	Left upper Receiver	19388	43	Long Tank Adapter Bolt	19439
9	Bolt Plug	19389	44	Short Tank Adapter Bolt	19440
10	Barrel Adapter	19391	45	Valve Snap Ring	19442
11	Valve Body	19392	46	Trigger Guard Screw	19443
12	Internal valve seat	19393	47	Internal Valve Spring	19444
13	Plunger Cup	19394	48	Bolt Handle Rubber Cover	19445
14	Rear Valve Seat	19395	49	Trigger Return Spring	19446
15	Single Trigger Assembly	19396	50	Drive Spring	19447
16	Left Lower Receiver	19397	51	Drive Spring Guide	19448
17	Trigger Guard	19399	52	Sear Spring	19449
18	Lower Receiver Acorn Nut	19400	53	Barrel Adapter O-Ring	19452
19	Lower Receiver Screw	19401	54	Bolt handle	19454
20	Trigger Plate	19402	55	Rear Bolt	19455
21	Trigger Plate Spacer	19404	56	Front Sight Rail	20169
22	Sear	19405	57	Magazine Retention Screws	20170
23	Right Upper Receiver	19406	58	Magazine Holder Nut	20172
24	Safety with O-Rings	19407	59	Delta Barrel Assembly	20190
25	Front Bolt	19409	60	Magazine Assembly	20191
26	Linkage Arm	19410	61	Magazine Locking Arm	20194
27	Long Receiver Bolt	19413	62	Stock Assembly	20195
28	Short Receiver Bolt	19414	63	Rear Sight Rail Assembly	20196
29	Receiver Nuts	19415	64	Valve Stem	99126
30	Valve Screw	19416	not shown	Complete Valve	19382
31	Right Lower Receiver	19417			
32	Velocity Screw	19418			
33	Grip Upper Hex	19419			
34	Tank Adapter Nuts	19423			
35	Front Bolt O-Ring	19424			



EMPIRE BT-4 SERIES MARKERS

Empire BT Delta Elite™ Parts List

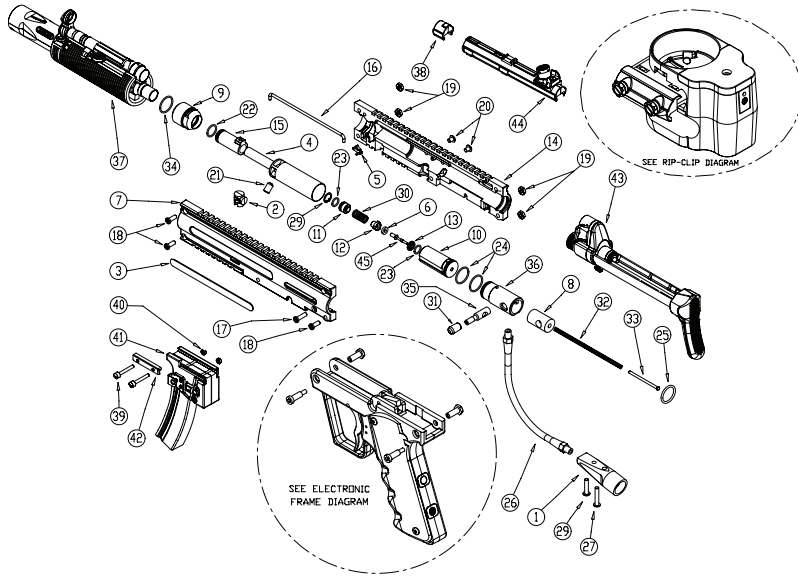

SCHEMATIC#	DESCRIPTION	SKU#	SCHEMATIC#	DESCRIPTION	SKU#
1	Tank Adapter	17044	31	Bolt Handle Rubber Cover	19445
2	Expansion Chamber Plug	17045	32	Drive Spring	19447
3	Delta Elite Name Plate	17055	33	Drive Spring Guide	19448
4	Power tube	19384	34	Barrel Adapter O-Ring	19452
5	Ball Detent	19386	35	Bolt handle	19454
6	Cup Seal	19387	36	Rear Bolt	19455
7	Left upper Receiver	19388	37	Delta Elite Apex Barrel Assembly	20166
8	Bolt Plug	19389	38	Front Sight Rail	20169
9	Barrel Adapter	19391	39	Magazine Retention Screws	20170
10	Valve Body	19392	40	Magazine Holder Nut	20172
11	Internal valve seat	19393	41	Magazine Assembly	20191
12	Plunger Cup	19394	42	Magazine Locking Arm	20194
13	Rear Valve Seat	19395	43	Stock Assembly (complete)	20195
14	Right Upper Receiver	19406	44	Rear Sight Rail Assembly (complete)	20196
15	Front Bolt	19409	45	Valve Stem	99126
16	Linkage Arm	19410	not shown	Complete Valve	19382
17	Long Receiver Bolt	19413			
18	Short Receiver Bolt	19414			
19	Receiver Nuts	19415			
20	Valve Screw	19416			
21	Velocity Screw	19418			
22	Front Bolt O-Ring	19424			
23	Internal Valve O-Ring	19425			
24	Rear Bolt & External Valve O-Ring	19426			
25	Shock Absorber O-Ring	19427			
26	Gas Line	19435			
27	Long Tank Adapter Bolt	19439			
28	Short Tank Adapter Bolt	19440			
29	Valve Snap Ring	19442			
30	Internal Valve Spring	19444			



EMPIRE BT-4 SERIES MARKERS

Empire BT Omega™ Parts List

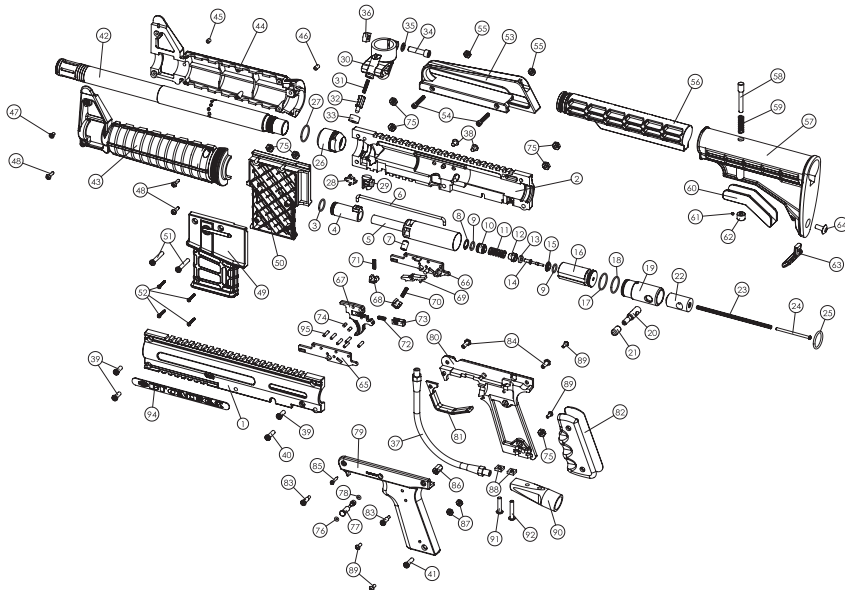

SCHEMATIC#	DESCRIPTION	SKU#	SCHEMATIC#	DESCRIPTION	SKU#
1	Left Upper Receiver	19388	39	Long Receiver Bolt	19413
2	Right Upper Receiver	19406	40	Short Receiver Bolt	19414
3	Front Bolt O-Ring	19424	41	Short Receiver Bolt	19414
4	Front Bolt	19409	65	Trigger Plate	19402
5	Power Tube	19384	66	Trigger Plate	19402
6	Linkage Arm	19410	68	Trigger Plate Spacer	19404
7	Velocity Screw	19418	69	Sear	19405
8	Valve Snap Ring	19442	70	Sear Spring	19449
9	Internal Valve O-Ring	19425	71	Trigger Return Spring	19446
9	Internal Valve O-Ring	19425	75	Receiver Nuts	19415
10	Internal Valve Seat	19393	75	Receiver Nuts	19415
11	Internal Valve Spring	19444	79	Left Lower Receiver	19397
12	Plunger Cup	19394	80	Lower Right Receiver	19417
13	Cup Seal	19387	81	Trigger Guard	19399
14	Valve Stem	99126	82	45 Rubber Grip	19429
15	Rear Valve Seat	19395	83	Lower Receiver Screws	19401
16	Valve Body	19392	84	Long Receiver Acorn Nut	19400
17	Rear Bolt & External Valve O-Ring	19426	85	Trigger Guard Screw	19443
18	Rear Bolt & External Valve O-Ring	19426	86	Grip Upper Hex	19419
19	Rear Bolt	19455	87	Lower Grip Nut	19383
20	Bolt Handle	19454	88	Tank Adapter Nuts	19423
21	Bolt Handle Rubber Cover	19445	89	Grip Screws	19430
22	Bolt Plug	19389	89	Grip Screws	19430
23	Drive Spring	19447	90	Tank Adapter	17044
24	Drive Spring Guide	19448	91	Short Tank Adapter Bolt	19440
25	Shock Absorber O-Ring	19427	92	Long Tank Adapter Bolt	19439
26	Barrel Adapter	19391	94	Empire BT Omega Side Plate	17107
27	Barrel Adapter O-Ring	19452	95	Trigger Plate Dowel Pins	19436
28	Ball Detent	19386	30-33	Feedneck Assembly (Complete)	19385
29	Expansion Chamber Plug	17045	42-48	Barrel Shroud Assembly (Complete)	17106
34	Standard Feed Elbow Pinch Bolt	19420	49-52, 75	Magazine Assembly (Complete)	17109
35	Standard Feed Elbow Washer	19422	53-55	Sight Rail Assembly (Complete)	17108
36	Standard Feed Elbow Nut	19421	56-64	Complete Stock Assembly	19280
37	Gas Line	19435	67, 72, 73, 74	Single Trigger Assembly	19396
38	Valve Screw	19416	76-78	Safety w/O-Rings	19407
39	Short Receiver Bolt	19414			



EMPIRE BT-4 SERIES MARKERS

Electronic Grip Parts List

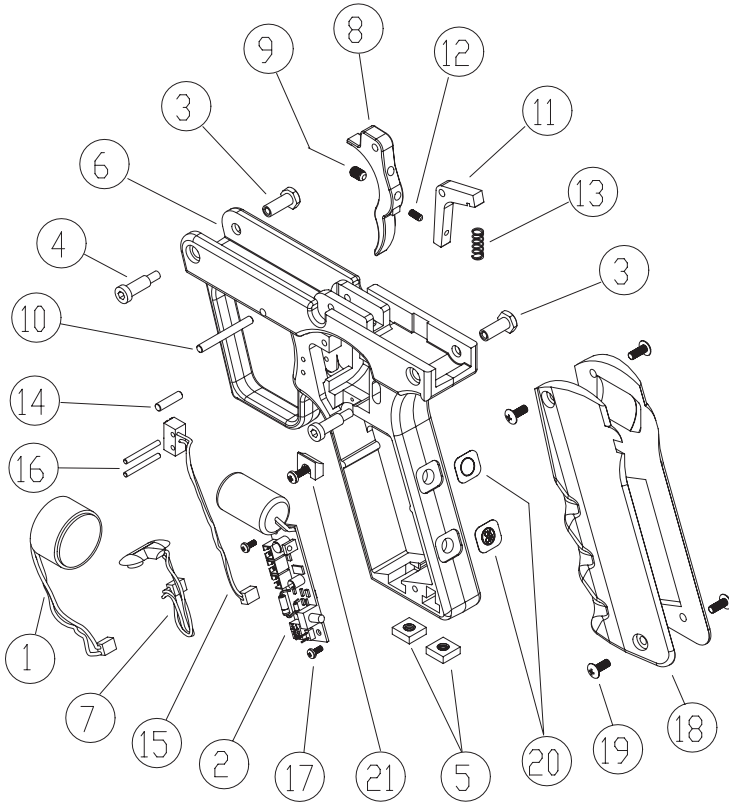

SCHEMATIC#	DESCRIPTION	SKU#
1	Solenoid (complete)	17046
2	Circuit board	19378
3	Lower Receiver Acorn Nut	19400
4	Lower Receiver Screw	19401
5	Tank Adapter Nuts	19423
6	Frame	20167
7	Battery Harness	20168
8	Trigger	20175
9	Trigger Set Screw	20176
10	Trigger Pin	20177
11	Sear	20178
12	Sear Set Screw	20179
13	Sear Spring	20180
14	Sear Pin	20181
15	Trigger Switch	20182
16	Trigger Switch pin	20183
17	Circuit Board Screw	20184
18	Grips	20185
19	Grip Screws	20186
20	Frame Decals (2pc)	20187
21	Solenoid Retainer (2pc)	20188



EMPIRE BT-4 SERIES MARKERS

Warranty Information

LIMITED LIFETIME WARRANTY INFORMATION

(ORIGINAL PURCHASE RECEIPT REQUIRED)

Empire BT Paintball warrants that this product is free from defects in materials and workmanship for as long as it is owned by the original purchaser, subject to the terms and conditions set forth below. Empire BT Paintball will repair or replace with the same or equivalent model, without charge, any of its products that have failed in normal use because of a defect in material or workmanship.

Empire BTPaintball is dedicated to providing you with products of the highest quality and the industry's best product support available for satisfactory play.

Purchaser should register product to activate warranty. Register your product by:

1. Online at www.paintballsolutions.com
2. Complete the product registration card (if applicable) and mail along with a copy of your receipt to Paintball Solutions, 11723 Lime Kiln Rd., Neosho, MO 64850.

WHAT THIS WARRANTY DOES NOT COVER

This warranty does not cover problems resulting from abuse, the unauthorized modification or alteration of our product, problems resulting from the addition of aftermarket products and scratches or minor superficial imperfections. Due to the nature of paintball products it is important that the product be maintained by the user as indicated in the product manual to remain in good operating condition. Your Limited Lifetime Warranty will be void if you fail to maintain the product as recommended in the product instruction manual. In addition, certain parts of a product may be subject to wear through regular usage. Replacement and repair of such parts is the responsibility of the user throughout the life of the product. These parts are not covered under the Limited Warranty. Examples of this type of part include (but are not limited to) goggle lens, straps, O-ring seals, cup seals, springs, ball detents, batteries, hoses, drive belts, gears and any part of a product subject to continuous impact from paintballs. Hydrotesting of air cylinders is not covered under this warranty.



The Limited Lifetime Warranty also does not cover incidental or consequential damages. This warranty is the sole written warranty on Empire's product and limits any implied warranty to the period that the product is owned by the original purchaser. Some states, provinces and nations do not allow the limitation of implied warranties or of incidental or consequential damages, so the above limitations or exclusions may not apply to you. This warranty gives you specific legal rights and you may also have other rights which vary from state to state, province to province, nation to nation.

If you should encounter any problems with your product and you have added aftermarket parts on your product, please test it with the original stock parts before sending it in. Always unload and remove air supply before shipping markers. Do not ship your air supply tank if it is not completely empty. Shipping a pressurized air supply tank is unsafe and unlawful. Remove all batteries from products prior to shipping.

This Limited Warranty gives you specific legal rights, and you may also have other rights which vary from state to state. Some states do not allow the exclusion of incidental or consequential damages.

For warranty parts, service or information in the U.S., contact:
Paintball Solutions • www.paintballsolutions.com
E-mail: tech@paintballsolutions.com • Phone: 1-800-220-3222

In Canada, contact:
Paintball Solutions
98 Bessemer Ct.
Unit 4
London, ON N6E 1K7
1-866-685-0030



EMPIRE BT-4 SERIES MARKERS



WARNING! PAINTBALL GUNS AND PAINTBALL GUN ACCESSORIES ARE NOT TOYS!

- Careless use or misuse may result in serious bodily injury or death!
- Eye protection designed for paintball must be worn by the user and all persons within range.
- Not for sale to persons under 18 years of age.
- Must be 18 years of age or older to operate or handle any paintball gun and paintball gun accessories without adult or parental supervision.
- Read and understand all cautions, warnings, and operating manuals before using any paintball gun or paintball gun accessory.
- Do not aim paintball gun at eyes or head of people or at animals.
- Paintball guns are to be used with Paintballs only.
- To prevent fire or shock hazard, do not expose unit to rain or moisture.
- To prevent fire or shock hazard, do not immerse unit in liquids.
- To prevent fire or shock hazard, do not disassemble any electronic paintball device.
- The disposal of the battery used to power this product may be regulated in your area.
- Please conform to all local or state regulations with regard to battery disposal.
- Use common sense and have fun.

Any tampering with the unit voids your warranty. There are no consumer serviceable parts inside the unit. The use of non factory authorized components within this product may cause a critical failure, fire or shock hazard.

IN NO EVENT SHALL SELLER BE LIABLE FOR ANY DIRECT, INCIDENTAL OR CONSEQUENTIAL DAMAGES OF ANY NATURE, OR LOSSES OR EXPENSES RESULTING FROM ANY DEFECTIVE PRODUCT OR THE USE OF ANY PRODUCT.

WARNING: This product contains one or more chemicals that are known to the State of California to cause cancer and birth defects or other reproductive harm. *Wash hands after handling.* You must be at least 18 years of age to purchase this product. This product may be mistaken for a firearm by law enforcement officers or others. Altering the color of the product or brandishing the product in public may be considered a crime.



WARNING!

Eye protection designed specifically for paintball must be worn by the user and persons within range. Safety is no accident.



EMPIRE BT-4 SERIES MARKERS

EMPIRE BATTLE TESTED PAINTBALL
11723 Lime Kiln Rd., Neosho, MO 64850
www.empirepaintball.com