

# ***STORMER***

## **Owner's Manual**

Manuel d'utilisateur  
Manual del Usuario



BASIC



ELITE



TACTICAL

# **TIPPMANN**

Kore Outdoor (US) Inc  
4230 Lake Avenue, Fort Wayne, IN 46815 USA  
1-800-671-9963  
[www.Tippmann.com](http://www.Tippmann.com)

TP04800  
88038  
Rev. 12/24

 **WARNING**

**This is not a toy. Misuse may cause serious injury or death. Eye, face, and ear protection designed for paintball must be worn by the user and any person within range. We recommend you be at least 18 years old to purchase. Persons under 18 must have adult supervision when using this product. Read the Owner's Manual before using this product.**

 **AVERTISSEMENT**

**Ceci n'est pas un jouet. Une mauvaise utilisation peut causer de sérieuses blessures ou entraîner la mort. Une protection spécifique au paintball pour les yeux, la tête et les oreilles doit être utilisée par l'utilisateur ainsi que par toute personne située dans le champ de tir. Nous recommandons que l'acheteur ait au moins 18 ans. Les personnes de moins de 18 ans doivent être surveillées par un adulte durant l'utilisation de ce produit. Lisez le manuel d'utilisation avant d'utiliser ce produit.**

 **ADVERTENCIA**

**Esto no es un juguete. Un uso inapropiado puede causar serias heridas o la muerte. Ojos, cara y oídos deben ser protegidos todo el tiempo, con la protección diseñada para paintball tanto por jugadores como por cualquier persona que este en el radio de alcance. Recomendamos al menos 18 años para la compra y uso. Las personas menores de 18 años deben usar este producto bajo la supervisión de un adulto. Lea el Manual del Usuario antes de usar este producto.**

## WARNING

### Safety is Your Responsibility

Read and familiarize yourself and any other user of this marker with the safety instructions in this manual. Follow these instructions when using, working on, transporting, or storing this marker.

Always keep the trigger safety in Safe mode unless firing as detailed in instructions on page 6.

Always keep the barrel blocking device installed when not in a shooting situation, see instructions on page 4.



## AVERTISSEMENT

### La Sécurité est Votre Responsabilité

Lisez et familiarisez-vous ainsi que tout autre utilisateur de ce lanceur avec les instructions de sécurité contenues dans ce manuel. Suivez ces instructions lorsque vous utilisez, travaillez sur, transportez, ou entreposez ce lanceur.

Si vous ne tirez pas, maintenez toujours la sécurité de la détente en mode sécurité comme indique dans les instructions en page 3.

Gardez toujours le dispositif de blocage du canon installé lorsque vous n'êtes pas en situation de tir comme indique dans les instructions en page 1.



## ADVERTENCIA

### La Seguridad es Su Responsabilidad

Lea y familiarícese usted y cualquier otro usuario de este marcador con las instrucciones de seguridad de este manual. Siga estas instrucciones cuando se utiliza, trabajando, transporte, o almacenar este marcador.

Mantenga siempre el seguro del gatillo activado a menos que sea necesario hacer disparos.

Como se ve en las instrucciones de la página 3.

Mantenga el mecanismo de bloqueo del barril instalado cuando no este haciendo disparos como se ilustra en la página 1.



## ⚠ WARNING

This is not a toy. Misuse may cause serious injury or death. Eye, face, and ear protection designed for paintball must be worn by the user and any person within range. We recommend you be at least 18 years old to purchase. Persons under 18 must have adult supervision when using this product. Read the Owner's Manual before using this product.

## ⚠ WARNING

Always keep the barrel blocking device installed except when your marker is in use. Always make sure that the Selector Switch is in the Safe mode (see instructions on page 6) and the barrel blocking device is properly installed on your marker according to the instructions to prevent damage to property, serious injury, or death.

### Barrel Blocking Device Installation Instructions

1. Insert the barrel blocking device onto the Barrel and loop the cord over the top of the receiver and position at the back of the grip as shown.
2. Adjust the cord length retainer up to the back of the grip by pulling the cord through it until the retainer is snug against the back of the grip. Keeping the cord as tight as possible, leave just enough cord elasticity to pull the cord/retainer up over the top of the marker to remove the barrel blocking device for firing.
3. After the cord length is properly adjusted, lock the cord length by tying a knot in the cord against the back of the retainer as shown.
4. Before and after playing, inspect the barrel blocking device. Replace the barrel blocking device if the sleeve or cord is damaged, or there is a loss of cord elasticity.
5. Clean the barrel blocking device with plain, warm water and store out of sunlight in a dry area when not in use.

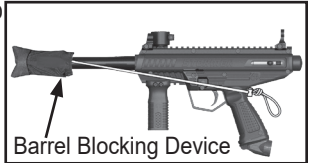

# **STORMER**<sup>®</sup>

Manufactured by **TIPPMANN**<sup>®</sup>

**Kore Outdoor (US) Inc**

4230 Lake Ave, Fort Wayne, IN 46815 USA

1-800-671-9963 • [www.Tippmann.com](http://www.Tippmann.com)

**Kore Outdoor Ltd - UK**

Adrenalin House, Brooklands Park, Farningham Road, Crowborough TN6 2JD UK

Telephone (+44) (0)1892-660105

Tippmann Paintball is a brand of Kore Outdoor US Inc.

CONGRATULATIONS on your purchase of your Stormer paintball marker. This marker will provide many years of dependable service if cared for properly.

Please take time to read this manual thoroughly and become familiar with your Stormer marker's parts, operation, and safety precautions before you attempt to load or fire this marker. If you have a missing or broken part, or need assistance, please contact Tippmann Consumer Relations at 1-800-671-9963 for fast, friendly service.

## **Table of Contents**

Barrel Blocking Device Installation Instructions.....	4
Warning/Liability Statement.....	6
Safety Is Your Responsibility! .....	6
Getting Started .....	8
1. Air/CO2 Supply Cylinder Installation .....	8
2A. Loading the Hopper (option) .....	8
2B. Removing the Magazine and Loading (option) .....	9
3. Firing Your Marker.....	9
4. Velocity Adjustment .....	9
5. Flip Up Sights (option).....	10
Unloading Your Marker .....	10
Air/CO2 Supply Cylinder Warnings.....	11
Air/CO2 Supply Cylinder Safety Tips .....	12
Air/CO2 Supply Cylinder Removal .....	12
Repairing Air/CO2 Supply Cylinder Leaks .....	13
Cleaning and Maintenance.....	13
Storage.....	14
Marker Disassembly and Assembly.....	14
Rear Bolt Removal.....	16
Front Bolt, Power Tube, and Valve Removal.....	16
Converting from Hopper Fed to Magazine Fed.....	16
Loading the Mag Fed Magazine.....	16
Magazine Disassembly, Reassembly, and Testing.....	17
Installing Marker Options.....	19
Ball Latch .....	19
Magazine Well.....	19
Barrel Shroud.....	19
Front Grip.....	19
Adjustable Stock .....	20
Stormer Marker Specifications .....	20
Stormer Marker Variations.....	21
Warranty and Repair Information .....	27

## Warning/Liability Statement

This marker is classified as a dangerous weapon and is surrendered by Kore Outdoor (US) Inc with the understanding that the purchaser assumes all liability resulting from unsafe handling or any action that constitutes a violation of any applicable laws or regulations. Kore Outdoor (US) Inc shall not be liable for personal injury, loss of property or life resulting from the use of this weapon under any circumstances, including intentional, reckless, negligent or accidental discharges.

All information contained in this manual is subject to change without notice. Kore Outdoor (US) Inc reserves the right to make changes and improvements to products without incurring any obligation to incorporate such improvements into products previously sold.

If you as a user do not accept liability, Kore Outdoor (US) Inc requests you do not use a Kore Outdoor (US) Inc marker. By using this paintball marker you release Kore Outdoor (US) Inc of any and all liability associated with its use.

## Safety Is Your Responsibility!

### **⚠ WARNING**

**Except when your marker is in use, always make sure that the trigger safety is in Safe mode, and that the barrel blocking device is properly installed (see page 4).**

**To turn on Safe mode (Push Safe):  
Push in the Safety button (location is shown at right).**

**To go to Fire mode (Push Fire): Push this same button from the opposite side of the receiver.**

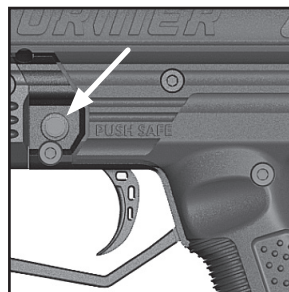

Push in on the **PUSH SAFE** button for Safe Mode.

### **Familiarize Yourself with Safety...**

The ownership of this marker places upon you the total responsibility of its safe and lawful use. You must observe the same safety precautions as you would any firearm to assure the safety of not only yourself but everyone around you. Outlined here are some general precautions to be aware of. The user should at all times use caution and common sense when using this marker and always remember that the game of paintball can only survive and grow if it remains SAFE!

- Do not load or fire this marker until you have completely read this manual and are familiar with its safety features, mechanical operation and handling characteristics.
- Handle this and any marker as if it were loaded at all times.
- Keep your finger off the trigger until you are ready to shoot.
- Do not look down the barrel of a paintball marker. Accidental discharge into the eyes may cause permanent injury or death.

- Keep the marker in Safe mode until ready to shoot (page 6).
- Keep the barrel blocking device installed on marker when not shooting (page 4).
- Never point the marker at anything you do not intend to shoot.
- Never fire your marker at anything you do not intend to shoot because there may be paintballs or foreign debris lodged in the chamber, barrel, and/or the marker valve.
- Do not shoot at fragile objects such as windows.
- Never fire your marker at personal property of others. The paintball impact can cause damage and the paint can stain the finish of automobiles, houses, etc.
- Always keep the muzzle pointed down or in a safe direction, even if you stumble or fall.
- Eye, face, and ear protection designed specifically to stop paintballs in the form of goggles and full face mask meeting ASTM Specification F 1776 must be worn by the user and any person within range.
- Never shoot at a person who is not protected by eye, face, and ear protection designed for paintball.
- Pressurize and load the marker only when the marker will be immediately used.
- Store the marker unloaded and degassed in a secure place.  
NOTE: Before storing or disassembling, be sure to remove paintballs and air/CO2 supply (see unloading and air/CO2 removal instructions on pages 10 -12) and install the barrel blocking device (see page 4).
- Do not field strip or otherwise disassemble this marker while it is pressurized with air/CO2 supply.
- Dress appropriately when playing the game of paintball. Avoid exposing any skin when playing the game of paintball. Even a light layer will absorb some of the impact and protect you from the paintballs.
- Keep exposed skin away from escaping gas when installing or removing air/CO2 cylinder or if the marker or air/CO2 supply is leaking. Compressed air, CO2, and nitrogen gasses are very cold and can cause frostbite under certain conditions.
- Use only .68 caliber paintballs. Never load or fire any foreign objects.
- Avoid alcoholic beverages before and during the use of this marker. Handling markers while under the influence of drugs or alcohol is a criminal disregard for public safety.
- Avoid shooting an opponent at point blank, 6 feet or less.
- Familiarize yourself with instructions listed on air/CO2 cylinder or adapter. Contact the air/CO2 cylinder or adapter manufacturer with any questions.
- Read the Air/CO2 Cylinder Warnings and Safety Tips on pages 10–11 before beginning the cylinder installation or removal.
- Always measure your marker's velocity before playing paintball and never shoot at velocities in excess of 300 feet per second (see instructions on page 9).
- Do not brandish or display this product in public as it may cause confusion and may be a crime. Police or others may mistake this product for a real firearm. Altering the coloration or markings required by state or federal law to make the product look more like a firearm is dangerous and may be a crime.

## Getting Started

- Eye protection designed for paintball use must be worn by the user and any person within range.
- Do not disassemble this marker while it is pressurized with air/CO<sub>2</sub>.
- Do not pressurize a partially assembled marker.
- Read each step completely before performing the step.

**NOTE:** Carefully hand start all threaded parts when assembling, and do not overtighten, as this may potentially strip the threaded parts.

### 1. Air/CO<sub>2</sub> Supply Cylinder Installation

Review Air/CO<sub>2</sub> Supply Cylinder Safety Tips (see page 11).

- Put the Trigger Safety in Safe mode (see page 6) and install the barrel blocking device (see page 4).
- As shown at right, cock the marker by sliding the bolt handle all the way back until it locks into place. Always keep marker in the cocked position when the air/CO<sub>2</sub> supply is attached to the marker. This helps prevent an accidental discharge.
- Lubricate the cylinder valve O-ring with marker oil.
- Insert the air/CO<sub>2</sub> supply cylinder valve into the air/CO<sub>2</sub> supply adapter (ASA) at the back end of the marker grip.
- Twist the cylinder clockwise into the air/CO<sub>2</sub> supply adapter until it stops. Use caution as the marker is now capable of firing after you put the Trigger Safety in Fire mode. If the tank is full, and you do not hear the air/CO<sub>2</sub> supply engage, the pin valve could be too short or the pin valve seal is damaged (follow the Air/CO<sub>2</sub> Supply Cylinder Removal instructions on page 12, and take your air or CO<sub>2</sub> cylinder to a "C5" Certified Airmith for inspection or contact the cylinder manufacturer).



Cocking the Marker

### 2A. Loading the Hopper (option)

The barrel blocking device must be installed (see page 4) and the Trigger Safety must be in Safe mode (see page 6).

- Make sure that the Feed Neck and Hopper are clean and free of sharp edges or debris. This keeps paintballs from breaking prematurely, and allows paintballs to feed to the marker's chamber smoothly.
- Loosen the Feed Neck Bolt using the included 3/16" hex key.
- Install the Hopper into the Feed Neck.
- Tighten the Feed Neck Bolt using the included 3/16" hex key. Do not over-tighten, as the Feed Neck may break.
- With the barrel blocking device installed (page 4), and the Trigger Safety in Safe mode (page 6), you are now ready to load your hopper with .68 caliber paintballs. Do not force excessive numbers of paintballs into the hopper. Fill the hopper only when ready to shoot. Remove the barrel blocking device and put the marker in Fire mode only when ready to shoot.



## 2B. Removing the Magazine and Loading (option)

The barrel blocking device must be installed (see page 4) and the trigger safety in Safe mode (see arrow at right and also see page 6).

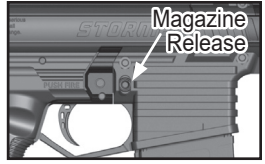

Two 20 round Magazines are provided with the marker.

- a. To remove the Magazine, push in the Magazine Release button and the Magazine ejects out the bottom of the Magazine Well (Mag Well).
- b. Use tabs on the side of the Carrier to pull it down until it locks into place at the bottom of the Magazine.
- c. Keep the Magazine vertical, and insert one paintball at a time into the top of the Magazine until full. Paintballs in the Magazine are not under pressure until the Magazine is inserted into the Mag Well.
- d. To insert a loaded Magazine into the Mag Well, slide the Magazine into the grip until you hear it lock into place.

## 3. Firing Your Marker

- a. Go to a designated firing area, remove the barrel blocking device, and move the Trigger Safety to Fire mode (see page 6).
- b. Point your marker in a safe direction and pull the trigger to fire the marker.
- c. When finished firing the marker, put the Trigger Safety in Safe mode (page 6) and install the barrel blocking device (page 4).

## 4. Velocity Adjustment

Each time you play paintball, check the velocity of your paintball marker with a chronograph (an instrument for measuring velocity) prior to playing paintball. Verify that the marker's velocity is set below 300 feet per second (or less if required by the playing field).

To adjust the marker's velocity, use the included 3/16" hex key. The velocity adjustment screw is located on left side receiver. To reduce the velocity, turn the screw inward or clockwise. To increase the velocity, turn the screw out or counterclockwise. Do not remove the velocity screw.

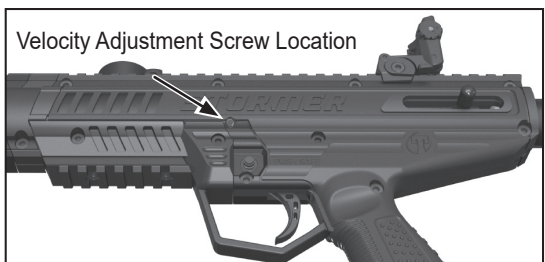

Use a 3/16" hex key to adjust the velocity.

## 5. Flip Up Sights (option)

The Front Flip Up Sight and the Rear Flip Up Sight can be in two positions. When flat against the Picatinny Rail, you can press the T (large arrow) or press the two tabs located on the sides of the sight (small arrow) to make them flip up for use.

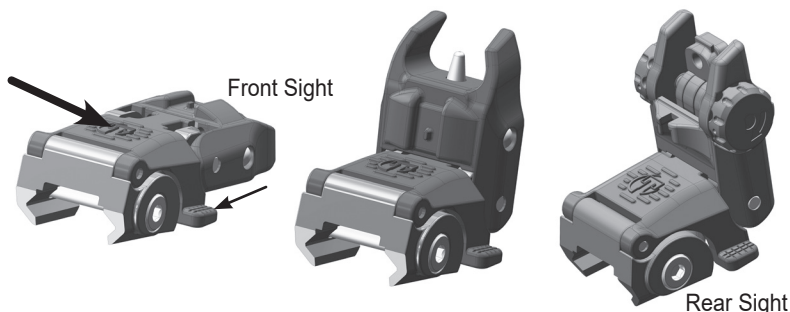

### Adjusting the Front Sight

1. The front sight is adjustable for elevation by moving the pin to lower or raise the bullet's point of impact
2. To adjust the front sight for elevation, turn the knob (arrow at right) left or right to move the point of impact up or down.

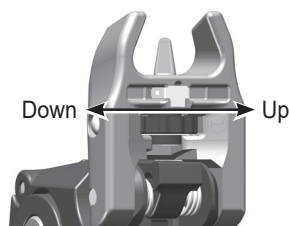

### Adjusting the Rear Sight

1. To adjust windage it is necessary to move the rear sight aperture left or right by using the knobs (black arrow) on the sides of the rear sight.
2. Turning the left windage adjustment knob counterclockwise moves the point of impact to the right.
3. Turning the left windage adjustment knob clockwise moves the point of impact to the left.

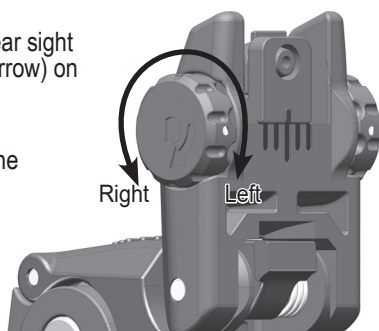

### Unloading Your Marker

1. Eye protection designed for paintball use must be worn by the user and any person within range. The Trigger Safety must be in Safe mode and the barrel blocking device must be installed.
2. Empty all paintballs from the Hopper or remove the Magazine from the marker.
3. Using the included hex key, loosen the Hopper Bolt and remove the Hopper from the Feed Elbow.
4. Go to a designated firing area, remove the barrel blocking device, and move the Trigger Safety to Fire mode (see page 6).
5. Point your marker in a safe direction and fire several times to be sure there are no remaining paintballs lodged in the chamber or barrel. **IMPORTANT:** Do not uncock your marker as uncocking your marker may push a ball into the chamber or down into the barrel in which case the ball will be hidden from view.

6. Return the Trigger Safety to the Safe mode (see page 6) and reinstall the barrel blocking device (see page 4).
7. Read the following Air/CO2 Supply Cylinder Warnings and Safety Tips before removing the air/CO2 cylinder from your marker (removal instructions are on page 12).

## Air/CO2 Supply Cylinder Warnings

### **⚠ WARNING**

**The brass or nickel plated cylinder valve (#1) is intended to be permanently attached to the air or CO2 cylinder (2). An air or CO2 cylinder can fly off with enough force to cause serious injury or death if the cylinder (2) unscrews from a cylinder valve (1).**

There have been reported incidents caused by players unknowingly unscrewing the cylinder (2) from the cylinder valve (1). This occurs when the player thinks the entire valve-cylinder assembly is being unscrewed from the air/CO2 supply adaptor of the paintball marker, when in fact he/she is unscrewing the cylinder from the cylinder valve.

To avoid this danger, it is recommended (if your cylinder is not already marked) that you use paint or nail polish to place a mark (3) on the cylinder valve, and place another mark (4) on the cylinder, in line with the #3 mark as shown.

Whenever you turn the cylinder during removal, watch the marks on the cylinder and the cylinder valve to be sure that they rotate together. If at any time these marks start to separate as shown at right, the cylinder is starting to unscrew from the cylinder valve and you must **STOP** and take the entire unit to a “C5” certified airsmith for safe removal and/or repair.

**NOTE:** The cylinder valve should unscrew from the paintball marker in about 3 or 4 full turns. If you finish the 4<sup>th</sup> full turn and the cylinder valve is not unscrewed from the paintball marker, **STOP!** Take the entire unit to a “C5” certified airsmith for safe removal and/or repair.

Locate a “C5” Certified Airsmith at [www.paintball-pti.com](http://www.paintball-pti.com).

Whether you have a new or used refillable air or CO2 cylinder, you are at risk if any of the following has occurred:

- The valve unit was replaced or altered after purchase.
- An anti-siphon device was installed.
- The valve unit was removed from the cylinder for any reason.
- Any modification was done to the refillable air or CO2 cylinder.

If any of these conditions has occurred, take your air or CO2 cylinder to a “C5” Certified Airsmith for inspection or contact the cylinder manufacturer.

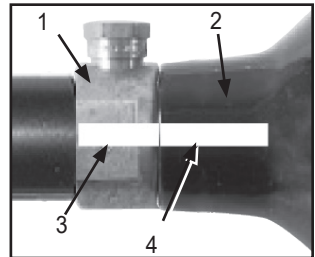

Properly marked Valve and Cylinder

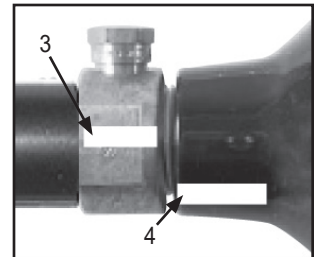

Misaligned Valve and Cylinder

## Air/CO2 Supply Cylinder Safety Tips

SAFETY TIPS to ensure that your air or CO2 cylinder is safe for play:

- Improper use, filling, storage, or disposal of air or CO2 cylinder may result in property damage, serious personal injury or death.
- Make sure that any maintenance or modification to any air or CO2 cylinder is done by a qualified professional, such as a “C5” certified airsmith.
- The use of anti-siphon devices is not recommended. However, if one is already installed on your air or CO2 cylinder or is desired, it is critical that your cylinder be checked by, or the device installed by, a qualified professional.
- All air or CO2 cylinders must be filled only by properly trained personnel.
- Cylinder valves must be installed only by properly trained personnel.
- Do not overfill a cylinder! Never exceed the air or CO2 cylinder’s capacity.
- Do not expose pressurized air or CO2 cylinder to temperatures exceeding 130 °F (55 °C).
- Do not use caustic cleaners or strippers on the air or CO2 cylinder or cylinder valve and do not expose to corrosive materials.
- Do not modify the air or CO2 cylinder in any way. Never try to disassemble the cylinder valve from the air or CO2 cylinder.
- Any air or CO2 cylinder that has been exposed to fire or heated to a temperature of 250 degrees Fahrenheit (121 degrees Celsius) or more must be destroyed by properly trained personnel.
- Use appropriate gas for your cylinder. Only use CO2 in a CO2 cylinder and only use compressed air in a compressed air cylinder.
- Keep all cylinders out of the reach of children.
- The Air or CO2 cylinder should be inspected and hydrostatically retested at least every 5 years by a DOT licensed agency.
- Keep exposed skin away from escaping gas when installing or removing air/CO2 supply, or if the marker or air/CO2 supply is leaking. Compressed air and CO2 gasses are very cold, and can cause frostbite under certain conditions.

**NOTE:** Locate a “C5” certified airsmith at [www.paintball-pti.com](http://www.paintball-pti.com)

## Air/CO2 Supply Cylinder Removal

1. Read *Air/CO2 Supply Cylinder Warnings* (page 10) and *Air/CO2 Supply Cylinder Safety Tips* (page 11) before beginning the cylinder removal process.
2. Eye protection designed for paintball use must be worn by the user and any person within range.
3. Follow the *Unloading Your Marker* instructions on page 10.
4. Watch the marks on the cylinder and cylinder valve (as shown on page 11) as you turn the cylinder approximately  $\frac{3}{4}$  turn counterclockwise. This allows the air/CO2 supply pin valve to close so that no air/CO2 will enter the marker.
5. Remove the barrel blocking device. Set the Trigger Safety to Fire mode. Point the marker in a safe direction, and discharge the remaining gas in the marker by repeatedly pulling the trigger until the marker stops firing (this may take 4-5 shots). If your marker continues to fire, the cylinder’s pin valve has not closed yet (the cylinder pin valve could

be longer than usual. Because of the variances in cylinder pin valve parts, each cylinder varies slightly on exactly how far it has to be turned). Turn the cylinder counterclockwise a little further and repeat this step until the marker does not fire. Only then remove the air/CO2 supply cylinder.

NOTE: If during this step, you turned the air/CO2 supply cylinder and it began to leak before you pulled the trigger, the cylinder O-ring should be checked for damage before any re-assembly (see *Repairing Air/CO2 Supply Cylinder Leaks* below).

6. After the air/CO2 supply cylinder is removed, again point and fire the marker in a safe direction to verify the marker is completely discharged of gas.
7. Move the Trigger Safety to the Safe mode (see page 6) and install the barrel blocking device (see page 4).

## Repairing Air/CO2 Supply Cylinder Leaks

The most common leak occurs from a bad air/CO2 supply valve O-ring. To replace a valve O-ring you must first remove the bad O-ring and then install a new one. This O-ring is located on the tip of your air/CO2 supply valve. The best valve O-rings are made of urethane. Urethane O-rings are not affected by high air/CO2 supply pressures. These may be purchased from Tippmann or your local paintball dealer.

**NOTE:** If a new air/CO2 supply valve O-ring does not resolve an air/CO2 supply leak, do not attempt to repair the air/CO2 supply cylinder. Contact Kore Outdoor (US) Inc, your local paintball dealer, or a "C5" Certified Airmith.

## Cleaning and Maintenance

- To reduce the chance of an accidental discharge, follow *Unloading Your Marker* (on page 10) and *Air/CO2 Supply Cylinder Removal* (on page 12).
- Eye protection (safety glasses) must be worn.
- Read and follow air/CO2 supply cylinder warnings and safety tips on pages 10-11.
- Do not disassemble a marker while it is pressurized with air/CO2.
- Do not pressurize a partially assembled marker.
- Follow warnings listed on the air/CO2 supply cylinder for handling and storage.
- Familiarize yourself with instructions listed on air/CO2 supply cylinder.
- Contact the air/CO2 supply cylinder manufacturer with any questions.
- Do not use any petroleum based cleaning solvents.
- Do not use any cleaning solvents that come in aerosol cans.

NOTE: Petroleum based products and aerosol products can damage your marker's O-rings.

To clean the exterior of your marker, use a damp towel to wipe off paint, grease, and debris.

### Hopper Fed

To clean inside the barrel, remove the Feed Tube. Unscrew the Locking Cap from the Feed Tube. Rotate the Feed Tube out to remove it from the marker. Insert the squeegee into the breech. Pull squeegee through the barrel to remove paint or debris.

## Magazine Fed

To clean inside the barrel, remove the Magazine. Insert the squeegee into the breech going through the Magazine well. Pull squeegee through the barrel to remove paint or debris.

### Alternative Barrel Cleaning method:

You can also remove the barrel to pull the squeegee through it.

To maintain your marker in good working condition, inspect, clean, and replace any damaged parts.

Lubricate the marker's air/CO2 supply valve O-ring, and the internal Drive Assembly parts: the Front Bolt O-ring (item #27), the Rear Bolt O-ring (10), the Linkage Arm (25), the Drive Spring (5) and Guide Pin (3).

The best valve O-rings are made of urethane. Urethane O-rings are not affected by high air/CO2 supply pressures. These may be purchased from Tippmann® or your local paintball dealer. Use Tippmann marker oil to lightly lubricate the O-rings and springs. Inspect and lubricate the air/CO2 supply valve O-ring with a few drops of marker oil when attaching the air/CO2 supply cylinder.

## Storage

Before storage, unload the marker (page 10) and remove air/CO2 supply (see page 12). Put the Trigger Safety in Safe mode (see page 6) and install the barrel blocking device (see page 4). Before storing your marker make sure that the marker is cleaned and oiled (see Cleaning and Maintenance above) so that it does not rust. Store your marker with the bolt in the forward, uncocked position. Store your marker in a dry area.

When removing your marker from storage, make sure the Trigger Safety is in Safe mode (see page 6) and the barrel blocking device is installed (see page 4).

## Marker Disassembly and Assembly

Set up a workbench with plenty of workspace to make sure no small parts become lost. Follow these safety instructions at all times when disassembling or re-assembling your marker.

- First follow *Unloading Your Marker* on page 10 and *Air/CO2 Supply Cylinder Removal* instructions on page 12.
- Always wear eye protection (like Safety Glasses) when performing any marker disassembly or re-assembly.
- Do not pressurize a partially assembled paintball marker.
- Put the marker into the uncocked position. If your marker is cocked, hold onto the Bolt Handle, pull the Trigger, and slowly release the Bolt Handle forward to uncock the marker.

Disassembly instructions are listed here. To re-assemble, do the steps in the reverse order. Refer to the exploded parts diagram on pages 22 and 23. Item numbers of parts are in parenthesis.

1. Remove the **Barrel** (29), turn the Barrel counterclockwise from the Receiver. To reinstall it, turn it clockwise to thread it into the Receiver. Make sure the O-Ring (28) is lubricated with Tippmann Certified Marker Oil when re-assembling the barrel to the marker.

2. If applicable, remove the **Front Sight** (73) and **Rear Sight** (74) from the marker.

3. Remove the **Lower Pic Rail** by removing **Screws** (83) and (51).

Rotate this assembly downward. The point where the **Lower Grip Frame/Guard Assembly** (82) meets the Grip is a hinge-like attachment.

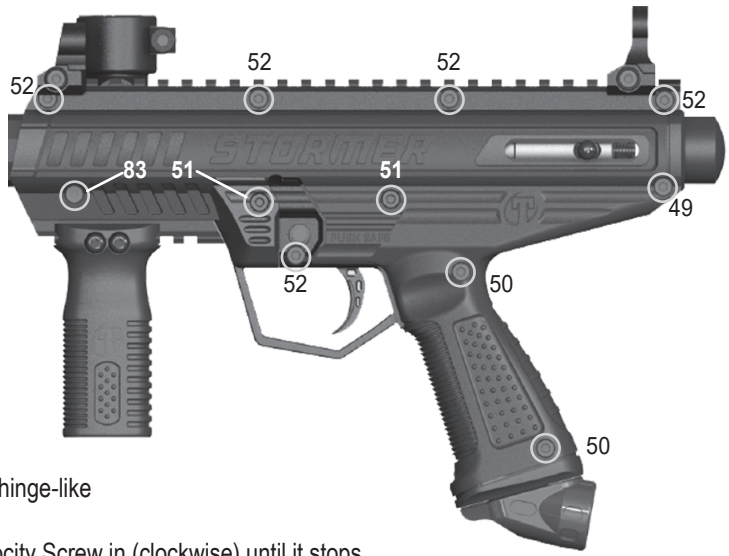

4. Turn the Velocity Screw in (clockwise) until it stops.

5. Remove the **Feed Elbow** (77) by removing the **Screw** (52). Set the Feed Elbow and Screw aside. For re-assembly, do not torque this screw more than 4.0 in-lb (0.45 N-m).

6. From the left side, remove the remaining Receiver Screws: one (49), two (50), one (51), and six (52), including one that is exposed when the Lower Grip Frame/Guard is removed. Remove the phillips Screw (46) from the right side Grip area. For re-assembly, do not torque these screws more than 8.0 in-lb (0.90 N-m).

7. To separate the marker halves, carefully lift the left Receiver Half (48) from the right Receiver Half (45).

8. Lift the **Safety** assembly (arrow) from the right Receiver Half.

9. Remove the **Trigger Link** (38) from the **Trigger** (33) and **Trigger Adapter** assembly (41). Lift the Trigger and **Spring** (34) from the marker. Lift the Trigger Adapter Assembly from the marker.

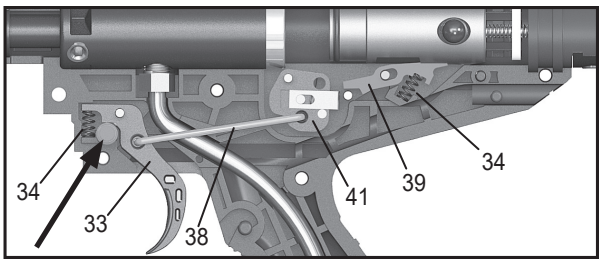

10. Remove the **Air Supply Adapter (ASA)** (31) and **Gas Line** (30) as an assembly from the marker. The Gas Line pulls out of the **Gas Line Joint** (22) attached to the Power Tube. Pull the Gas Line from the ASA if necessary.

11. Remove the **Sear** (39) by lifting straight up from the right Receiver half. Be sure to maintain control of the **Spring** (34) while removing the Sear.



## Rear Bolt Removal

1. Remove the **Guide Pin** (3), **Bumper** (4), and **Spring** (5). These parts must be removed before the **Rear Bolt Handle** (7) can be removed. Item 8 is the handle cover.
2. Remove the Rear Bolt Handle from the **Rear Bolt Plug** (6).
3. Inspect the **O-ring** (10) for damage, replace with a new one if damaged.

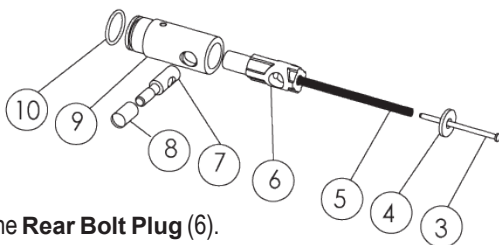

## Front Bolt, Power Tube, and Valve Removal

1. Disconnect the **Linkage Arm** (25) from the **Power Tube** (24) and **Front Bolt** (26).
2. Slide the Front Bolt off the Power Tube and check the **O-ring** (27). Clean and oil the O-ring, or if damaged, replace with a new one.
3. Do not remove the **Gas Line Joint** (22) from the Power Tube unless it is leaking or you need to replace the Valve. If you remove the Gas Line Joint, you will need some teflon tape or paste to reinstall it. A little marker oil on the O-ring will make reassembly easier.
4. To remove the Valve from the Power Tube, use a wrench to slowly unscrew the Gas Line Joint. Once the fitting is out, the Valve slides out the back of the Power Tube.
5. Check the external Valve **O-ring** (13) at this time. If the O-ring is damaged, your marker will not function correctly. Clean and oil the O-ring, or if damaged, replace with a new one.

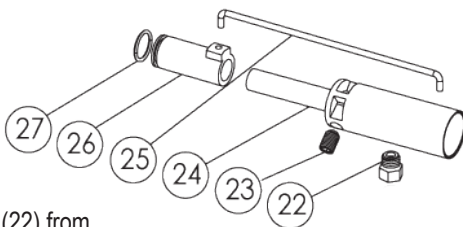

## Reinstalling the Valve into the Power Tube

1. Insert the Valve into the Power Tube.
2. Add teflon tape or paste to the Gas Line Joint threads.
3. Slowly screw the Gas Line Joint into the Valve by hand, and then snug with a wrench.

## Converting from Hopper Fed to Magazine Fed

1. Replace the Hopper Feed Tube with the Mag Fed Cover Plate (85). This Cover Plate contains the Ball Latch (80). The Ball Latch can be removed for replacement. The Mag Fed Ball Latch is different from the Loader Fed Ball Latch. They are not interchangeable. The Ball Latch Retaining Plate (86) holds the Ball Latch in place.
2. The Cover Plate is secured by Screw (52).
3. Remove the **Lower Grip Frame/Guard** (82) as described in step 3 under Disassembly.
4. Install the **Magwell & Guard** (87). Place the hooked part of the trigger guard into the grip, and rotate the assembly up to the marker. Secure to the marker with **Screws** (49).
5. When the Magazine is in the Magwell, it is released by the **Magazine Release Button** (87) for reloading. The release is spring-assisted so it quickly ejects the Magazine from the magazine well.

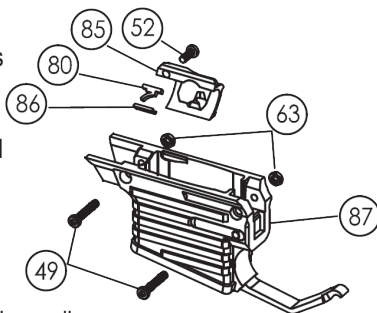



## Loading the Mag Fed Magazine

Loading instructions are molded into the side of the magazines.

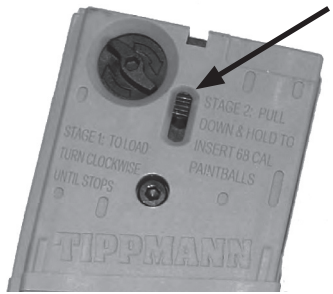

1. It is important to wind up the spring by rotating the knob on the magazine in the clockwise direction.
2. Paintballs may be inserted past the magazine ball catch, but if paintballs are fragile, we recommend retracting the ball catch release (arrow).
3. The Magazines hold 20 paintballs, but loading 19 is best. If magazines are to be carried in a battle pack, this ensures the 19 paintballs are not under any compression, compression may cause flat spots on the paintballs.

## Mag Cleaning

1. Clean the outside of the magazine with a soft cloth moistened with clean water. Do not use chemicals on the magazine.
2. Make sure the spring mechanism is NOT compressed.
3. The magazine has a removable lower half. To remove the lower half, remove the lower screw; this allows the ball piston and spring assembly to be removed as shown.
4. The remaining magazine assembly may be disassembled if desired. Refer to instructions below.
5. To reassemble do these steps in reverse. Place the spring and ball piston into magazine first, then assemble the lower panel back into place. Secure with the screw removed in step 3.



## Magazine Disassembly, Reassembly, and Testing

Read these instructions completely before attempting Magazine disassembly or reassembly.

### Magazine Disassembly

1. Set the Magazine on a workbench with the Left Shell side facing up.
2. Remove #4 x 5/8 Screws.
3. Gently disengage the top latch, then separate both halves of the Magazine.
4. Remove and clean the internal parts as necessary.

NOTE: If you clean the Carrier Spring with water, prevent rusting by thoroughly drying it and applying a light coating of Tippmann oil before reassembly.

### Magazine Reassembly

1. Place the Carrier Release Lever Spring into the Right Shell.
2. Properly orient the Carrier Release Lever onto the Carrier Release Lever Spring in the Right Shell.
3. Place the Magazine Latch and Carrier Release Armature into the Right Shell.
4. Set the Latch Spring between the Magazine Latch and the Carrier Release Armature. The Latch Spring sets in a pocket formed by the two parts inside the Right Shell.

5. Confirm that the Magazine Latch and Carrier Release Armature are oriented as shown in the circled area at below right. The flat surfaces of the Magazine Latch and the Carrier Release Armature fit together, and must align correctly for the Magazine to operate properly.

6. Place the Carrier Spring into the Right Shell.

7. Install the Left Shell onto the Right Shell, but do not fully press the two pieces together. Be sure the internal parts stay in their locations while putting the two shell halves together. The top latch of the Right Shell does not engage at this time.

8. Install the bottom #4 x 5/8 Screw. Tighten it until snug.

9. Place the Carrier onto the Carrier Spring (aligning the two tabs on the Carrier with the slots in the Left Shell and Right Shell) and slide down into the top of the assembled shell halves. Push down on the Carrier until it snaps into place inside the Magazine. Note that the Carrier has a flat side that goes against the Magazine Latch.

10. Push the top of the Magazine together so the Top Latch engages.

11. Install the remaining #4 x 5/8 Screws. Tighten them until they are snug.

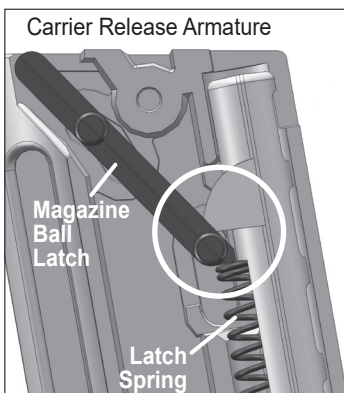
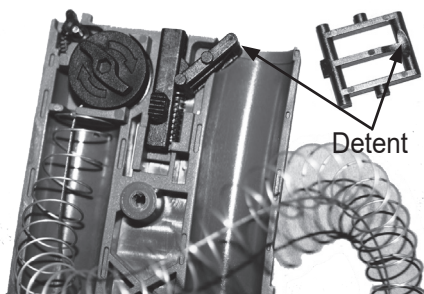

**Magazine Lubrication**

There is a small hole (circled at right) by the magazine detent latch located on the magazine.

A single drop of oil will ensure spring does not corrode. This spring is plated, but if left wet it could corrode, so we recommend a small application of single oil drop every 25 uses.



The spring wind up cord, ball piston, and ratchet wheel is an assembly. We do not recommend disassembly of these parts. Note that the spring is a 3 stage progressive spring to ensure even pressure and controlled tension as the ball stack releases, as it moves around the magazine ball channel.

**Magazine Testing**

1. Push down the Carrier. Make sure the Carrier moves freely.
2. While holding down the Carrier, push down on the Carrier Release Armature and ensure that the Magazine Latch moves freely.
3. Push down the Carrier all the way to the bottom of the Magazine until it locks into place.
4. Place a finger inside the top of the Magazine, then press down on the Carrier Release Armature to release the Carrier. Releasing the Carrier without a finger to stop it may result in the Carrier assembly breaking.

Magazine testing is complete.

## Installing Marker Options

### Ball Latch

Replace the Ball Latch by pushing up a hex key through the hole in the **Lower Grip Frame/Guard** (82).

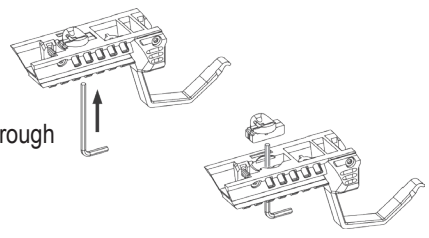

### Magazine Well

1. Replace the Hopper Feed Tube with the Mag Fed Cover Plate (85). This Cover Plate contains the Ball Latch (80). The Ball Latch can be removed for replacement. The Mag Fed Ball Latch is different from the Loader Fed Ball Latch. They are **not** interchangeable. The Ball Latch Retaining Plate (86) holds the Ball Latch in place.
2. The Cover Plate is secured by Screw (52).
3. Remove the **Lower Grip Frame/Guard Assembly** (87) as described in step 3 under Disassembly.
4. Install the **Magwell & Guard** (89). Place the hooked part of the trigger guard into the grip, and rotate the assembly up to the marker. Secure to the marker with **Screws** (49).
5. When the Magazine is in the Magwell, it is released by the **Magazine Release Button** for reloading. The release is spring-assisted so it quickly ejects the Magazine from the magazine well.

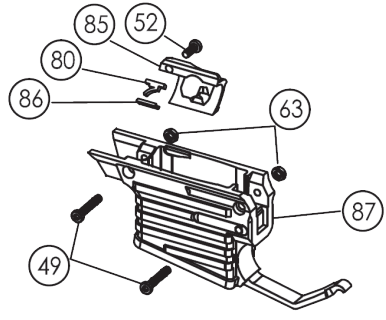

### Barrel Shroud

The Barrel Shroud can be installed on either the Hopper-fed marker or the Magazine-fed marker. Slide the Shroud over the Barrel and push towards the Receiver until you hear a click. The click sound is from the Shroud Latch securing to the Receiver (circled at right).



To remove the Shroud, press the thumbpad to disengage the latch. Slide the Shroud off of the Barrel.

### Front Grip

The Front Grip (65) can be installed to any Picatinny Rail using two 10-32 Screws (66).

### Adjustable Stock

1. If present on your marker, remove the End Cap Cover (1) from the End Cap (2).
2. Find a 10-32 x 1/2" screw (B) in the Accessory Pack.
3. Insert the Stock into the slots on the End Cap of the marker (A).
4. Insert and tighten the screw (B).

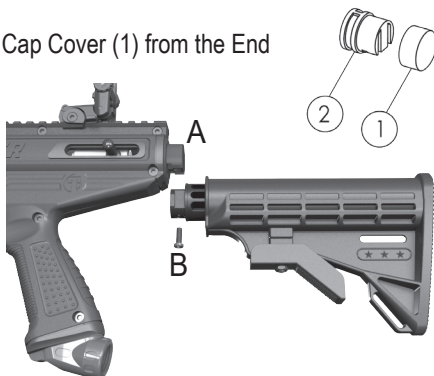

### Length Adjustment

1. Squeeze the Adjustment Lever.
2. Slide the Stock together or apart to the desired length.
3. Release the Adjustment Lever.

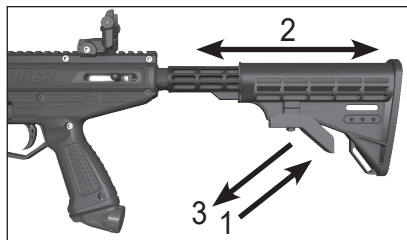

### Stormer Marker Specifications

Model.....	Stormer
Caliber .....	.68
Action.....	Semi-Automatic (open bolt blow-back)
Power/Air Supply.....	compressed air, nitrogen, or CO2
Hopper Capacity.....	200 Paintballs
Ball Feed .....	Gravity (Hopper) and Magazine Fed
Cycle Rate .....	8 shots per second
Standard Barrel Length .....	9.7" / 24.7 cm
Overall Length (with standard barrel, no cylinder).....	19.8" / 50.3 cm
Weight (without cylinder) .....	2.046 lbs. / 0.928 Kg
Effective Range .....	Adjustable, typically 150+ ft. / 46+ metres

Velocity: Always measure your marker's velocity before playing paintball and never shoot at velocities in excess of 300 feet per second (see instructions on page 9).

# Stormer Marker Variations



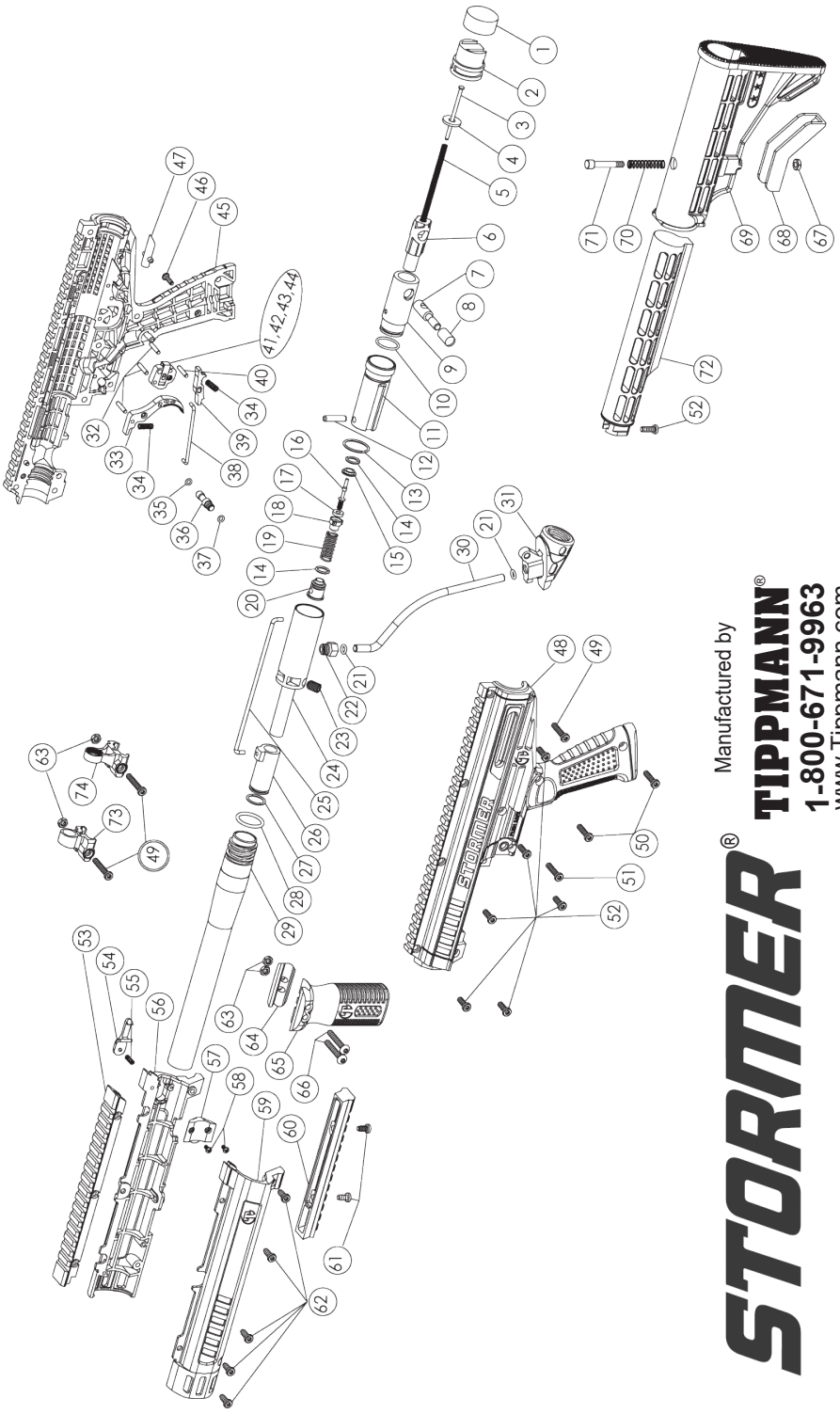

Rev. 10/05/19

Manufactured by  
**TIPPMANN®**  
 1-800-671-9963  
[www.Tippmann.com](http://www.Tippmann.com)

# STORMER®

# ⚠ WARNING

**Do not disassemble this marker while it is pressurized with air/CO2.  
Do not pressurize a partially assembled marker.**

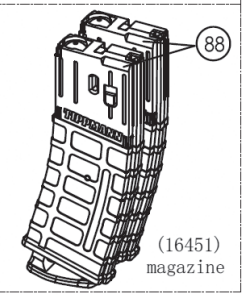
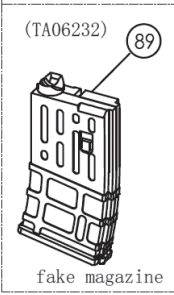
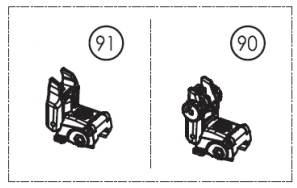
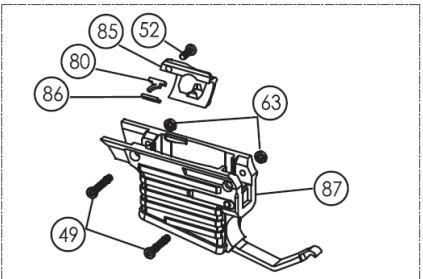
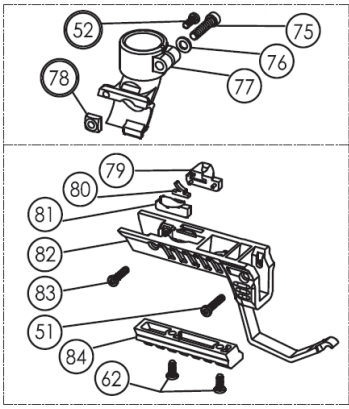

**Parts List for Stormer**

<b>Item No.</b>	<b>Part No.</b>	<b>QTY</b>	<b>Description</b>
1	76389	1	END CAP COVER
2	11917	1	END CAP
3	N/A	1	GUIDE SPRING
4	N/A	1	BUMPER
5	N/A	1	COMP.SPRING 4.312"FL-0.189"O.D.
6	11832	1	REAR BOLT PLUG
7	11688	1	REAR BOLT HANDLE
8	11832	1	REAR BOLT HANDLE COVER
9	11689	1	REAR BOLT
10	17928	1	SMALL REAR BOLT O-RING
11	94249	1	VALVE BODY
12	17917	1	VALVE LOCK PIN
13	11711	1	VALVE/REAR BOLT O-RING
14	11841	1	VALVE STEM O-RING
15	11907	1	FRONT VALVE SEAT
16	11841	1	VALVE STEM
17	11841	1	VALVE STEM CUP SEAL
18	11841	1	VALVE STEM CUP
19	77564	1	COMP. SPRING
20	11719	1	VALVE PLUG
21	11660	2	O RING
22	76374	1	GAS LINE JOINT
23	18318	1	VELOCITY SCREW 5/16-24 X 0.54"
24	17936	1	POWER TUBE
25	11771	1	LINKAGE ARM
26	18361	1	FRONT BOLT
27	18362	1	FRONT BOLT O-RING
28	11708	1	BARREL O-RING
29	N/A	1	BARREL
30	76242	1	GAS LINE
31	18319	1	TANK ADAPTER
32	N/A	3	RECEIVER DOWEL PIN
33	77095	1	SINGLE TRIGGER



<b>Parts List for Stormer</b>			
<b>Item No.</b>	<b>Part No.</b>	<b>QTY</b>	<b>Description</b>
34	76365	2	SEAR SPRING
35	11709	1	SAFETY O-RING BLACK
36	N/A	1	SAFETY PIN
37	11707	1	SAFETY O-RING RED
38	76245	1	TRIGGER LINKAGE ARM
39	11785	1	SEAR
40	N/A	1	DOWEL PIN/SEAR PIN BLACK
41	18328	1	TRIGGER ADAPTER
42	N/A	2	RETURN SLIDE DOWEL PIN
43	11739	1	TRIGGER RETURN SLIDE
44	76365	1	SEAR SPRING
45	N/A	1	RIGHT RECEIVER
46	N/A	1	SCREW
47	18339	1	ASA BLANKING PLATE
48	N/A	1	LEFT RECEIVER
49	N/A	5	SCREW,10-32 X 25.9MM LSHCS
50	N/A	2	10-32 BOLT 0.675
51	76249	2	SCREW,10-32 X 22.8MM LSHCS
52	77094	9	SCREW,10-32 X 1/2" LSHCS
53	N/A	1	UPPER SHROUD PIC RAIL & FRONT SIGHT
54	N/A	1	SHROUD LATCH
55	N/A	1	LATCH SPRING
56	N/A	1	SHROUD RIGHT
57	N/A	1	LATCH CLAMP PLATE
58	N/A	2	SELF TAPPER POSI DRIVE
59	N/A	1	SHROUD LEFT
60	N/A	1	LOWER PIC RAIL
61	N/A	2	1/8 SOCKET SELF TAPPER SCREW X 9MM
62	N/A	7	1/8 SOCKET SELF TAPPER SCREW X 11MM
63	11670	6	HEX NUT 10-32 X 5/16
64	N/A	1	FRONT GRIP CLAMP PLATE
65	N/A	1	FRONT GRIP
66	N/A	1	SCREW, 10-32 X 1.1875"

**Parts List for Stormer**

<b>Item No.</b>	<b>Part No.</b>	<b>QTY</b>	<b>Description</b>
67	N/A	1	NUT, HEX-BLACK 10-32
68	76214	1	COLLAPSIBLE STOCK RELEASE
69	11922	1	COLLAPSIBLE STOCK SLIDE
70	11922	1	COLLAPSIBLE STOCK SPRING
71	11922	1	COLLAPSIBLE STOCK LATCH BOLT
72	11922	1	COLLAPSIBLE STOCK FRAME
73	87565	1	FRONT SIGHT BASIC
74	87570	1	REAR SIGHT BASIC
75	77094	1	SCREW 1/4-20 X 1 SHCS
76	77094	1	WASHER M6 FLAT BLACK
77	77094	1	FEED ELBOW 68
78	77094	1	NUT,1/4-20 SQUARE-BLACK
79	N/A	1	BALL LATCH MOUNT
80	87573	2	MAG FED BALL LATCH
81	N/A	1	BALL LATCH MOUNT
82	N/A	1	LOWER GRIP FRAME/GUARD
83	N/A	1	TANK SCREW
84	N/A	1	LOWER PIC RAIL
85	87573	1	MAG FED COVER PLATE
86	87573	1	BALL LATCH RETAINER PLATE
87	87572	1	MAGWELL & GUARD ASSABLY
88	78845	1	MAGAZINE ASSEMBLY
89	87574	1	DUMMY MAGAZINE ASSEMBLY
90	76573	1	FRONT SIGHT FOLDING
91	76585	1	REAR SIGHT FOLDING

## Warranty and Repair Information

Kore Outdoor (US) Inc (“Tippmann”) is dedicated to quality paintball products and outstanding service. In the unlikely event of a problem with this Tippmann paintball marker (“Marker”) and/or Tippmann accessories (“Accessories”), Tippmann’s customer service personnel are available to assist you. For customer service and/or other information, please contact:

**Kore Outdoor (US) Inc**  
4230 Lake Avenue, Fort Wayne, IN 46815 USA  
1-800-671-9963 • [www.Tippmann.com](http://www.Tippmann.com)

**Kore Outdoor Ltd - UK**  
Adrenalin House, Brooklands Park, Farningham Road, Crowborough TN6 2JD UK  
Telephone (+44) (0)1892-660105

### Warranty Registration

To activate the Marker’s Limited Warranty, you must register the Marker within thirty (30) days of the date of original retail sale by registering online at [www.paintballsolutions.com/index.php/warranty-registration/.com](http://www.paintballsolutions.com/index.php/warranty-registration/.com)

The Limited Warranty for Tippmann Accessories does not require activation or registration; by registering the Marker, you activate the warranty for the Accessories.

### Limited Warranty

Tippmann warrants to the original purchaser that it will make any repairs or replacements necessary to correct defects in material or workmanship, at no charge to you, for the Marker for a period of one (1) year from the date of original retail sale. Further, Tippmann warrants to the original purchaser that it will make any repairs or replacements necessary to correct defects in material or workmanship, at no charge to you, for Tippmann Accessories for a period of ninety (90) days from the date of original retail sale. All Tippmann asks is that you properly maintain and care for the Marker and Accessories (collectively, the “Product”) and that you have warranty repairs performed by Tippmann or a Tippmann Certified Tech Center.

This Limited Warranty is non-transferable, and it does not cover damage or defects to the Product caused by (a) improper maintenance; (b) alteration or modification; (c) unauthorized repair; (d) accident; (e) abuse or misuse; (f) neglect or negligence; and/or (g) normal wear and tear.

Tippmann does not authorize any person or representative to assume or grant any other warranty obligation with the sale of this Product.

THIS IS THE ONLY EXPRESS WARRANTY GIVEN WITH THE PURCHASE OF THIS PRODUCT; ANY AND ALL OTHER EXPRESS WARRANTIES ARE DISCLAIMED. THE IMPLIED WARRANTIES OF MERCHANTABILITY AND FITNESS FOR A PARTICULAR PURPOSE ARE LIMITED TO THE APPLICABLE LIMITED WARRANTY PERIOD SET FORTH HEREIN, AND NO WARRANTIES, WHETHER EXPRESS OR IMPLIED, SHALL APPLY AFTER EXPIRATION OF SUCH PERIOD.

Some states and nations do not allow limitations on the duration of implied warranties, so the

above limitation may not apply to you.

The sole and exclusive liability of Tippmann and/or its authorized dealers under this Limited Warranty shall be for the repair or replacement of any part or assembly determined to be defective in material or workmanship. TIPPMANN SHALL NOT BE LIABLE FOR, AND YOU EXPRESSLY DISCLAIM, ANY DIRECT, INDIRECT, CONSEQUENTIAL OR INCIDENTAL DAMAGES (COLLECTIVELY, "DAMAGES") ARISING OUT OF THE SALE OR USE OF, OR YOUR INABILITY TO USE, THE PRODUCT. NO PAYMENT OR OTHER COMPENSATION WILL BE MADE FOR DAMAGES, INCLUDING INJURY TO PERSON OR PROPERTY OR LOSS OF REVENUE WHICH MIGHT BE PAID, INCURRED OR SUSTAINED BY REASON OF THE FAILURE OF ANY PART OR ASSEMBLY OF THE PRODUCT.

Some states and nations do not allow the exclusion or limitation of incidental or consequential damages, so the above limitation or exclusion may not apply to you. This warranty gives you specific legal rights, and you may also have other rights that may vary from state to state or nation to nation.

## Warranty and Non-Warranty Repairs

For Warranty parts, service, information or manuals in other languages, (where applicable) contact Paintball Solutions: [www.paintballsolutions.com](http://www.paintballsolutions.com)

E-Mail: [tech@paintballsolutions.com](mailto:tech@paintballsolutions.com)

US: 1-800-220-3222

4230 Lake Avenue, Fort Wayne, IN 46815

When shipping the Product to Kore Outdoor US Inc. for warranty or non-warranty repair:

1. If you have aftermarket parts on your Product, please test the Product with original stock parts before returning the Product for service or repair.
2. Disconnect any gas and/or air cylinders attached to your product and if sending any air cylinders back please make sure the bottles are completely drained of any air in the cylinder.
3. Always unload and remove the paintballs from the Product.
4. Ship the Product to the Tippmann address identified.
5. You must pre-pay postage and delivery charges, use a carrier that provides tracking information.
6. Provide the date of purchase for the Product.
7. Briefly describe the repair requested.
8. Include your name, return address, and a telephone number where you can be reached during normal business hours, if possible.

Tippmann makes every effort to complete its repair work within twenty-four (24) hours of receipt. Tippmann will return the Product to you via regular ground UPS. If you wish to have it returned using a faster service, you can request NEXT DAY AIR UPS or SECOND DAY AIR UPS, but you will be charged for this service and must include your credit card number with the expiration date. Your credit card will be charged the difference in additional cost over regular ground shipping service.



# ***STORMER***

## **Owner's Manual** **Manuel d'utilisateur** **Manual del Usuario**

### **Kore Outdoor (US) Inc**

4230 Lake Avenue, Fort Wayne, IN 46815 USA  
1-800-671-9963 • [www.Tippmann.com](http://www.Tippmann.com)

### **Kore Outdoor Ltd - UK**

Adrenalin House, Brooklands Park, Farningham Road, Crowborough TN6 2JD UK  
Telephone (+44) (0)1892-660105

Tippmann Paintball is a brand of Kore Outdoor (US) Inc

# **TIPPMANN®**

Kore Outdoor (US) Inc  
4230 Lake Avenue, Fort Wayne, IN 46815 USA  
1-800-671-9963  
[www.Tippmann.com](http://www.Tippmann.com)